

Preposed Negation in Danish

Bjarne Ørsnes

Freie Universität Berlin

Proceedings of the HPSG09 Conference

Georg-August-Universität Göttingen, Germany

Stefan Müller (Editor)

2009

CSLI Publications

<http://csli-publications.stanford.edu/>

Abstract

In Danish the base position of the negation and negated quantifier phrases is between the subject and the finite verb in embedded clauses. However, in embedded clauses introduced by a non-veridical complementizer such as *hvis* ('if') or *om* ('whether') the negation and negated quantifier phrases can also appear between the complementizer and the subject. This phenomenon is referred to as preposed negation. The paper investigates the structure and semantics of this construction. It is argued that preposed negation is no adjunction structure, but a special construction where the negation element is a sister of the complementizer and the filler of a filler-gap-structure. It is further argued that preposed negation is associated with negated verum-focus of a clause lacking an (aboutness-) TOPIC. The negation of a verum predicate explains why preposed negation fails to license strong negative polarity items and to rule out positive ones. The lack of a TOPIC explains why preposed negation is preferred with non-referential subjects and with weak readings of indefinite subjects and why preposed negation is incompatible with TOPIC-binding particles. The final section presents an HPSG-analysis of preposed negation using Minimal Recursion Semantics (MRS).

1 Introduction

In Danish non-V1/V2-clauses¹ sentential negation (and other sentential adverbs) appears between the subject and the finite verb thus marking the left-edge of the VP. Even non-subject negative quantifier phrases appear in the position of the sentential negation even though complements of the verb canonically follow the verbal head, cf. (1) and (2) below. I will refer to this as *ordinary negation*. Cf. the examples below.²

- (1) *fordi* *det ny system ikke tillader ansøgere under 15 år* (DK)
 because the new system not allows applicants under 15 years
 ‘because the new system does not allow applicants under 25 years’

¹I am especially indebted to Stefan Müller for numerous discussions and help with the analysis. Furthermore I wish to thank Jørg Asmussen, Philippa Cook, Felix Bildhauer, Jacob Maché, Line Mikkelsen, Patrizia Paggio, Roland Schäfer as well as the audience and reviewers of HPSG09 for discussion and comments. All remaining errors are my responsibility. This research is supported by the *Deutsche Forschungsgemeinschaft* under the grant nr. DFG (MU 2822/2-1).

²Here I use the term V1/V2-clauses for clauses where the finite verb precedes sentence adverbials, and the term non-V1/V2-clauses for clauses where the finite verb follows sentence adverbials. Here I will primarily be concerned with non-V1/V2-clauses as exemplified in (i).

- (i) *fordi* Peter ikke synger
 Because Peter not sings

²(DK) marks an example from KorpusDK (<http://ordnet.dk/korpusdk>), (I) an example from the Internet. Other examples are constructed. The authentic examples have been abridged and sometimes slightly modified for reasons of space.

- (2) hvis hun ingen erstatning fik, fordi motorcyklisten ikke
 if she no compensation became, because motor.cyclist.DEF not
 havde forsikret sig (DK)
 had insured himself
 ‘if she did not get any compensation, because the motor cyclist had no
 insurance’

However, in certain non-V1/V2-clauses there is a further possibility: sentential negation and non-subject negative quantifier phrases can also appear between the complementizer and the subject, as shown below. I will refer to this pattern as *preposed negation*.

- (3) og hvis ikke kunsten magter at vise det, er det ikke kunst (DK)
 and if not art.DEF is.capable.of to show this, is it not art
- (4) hvis ingen arvinger der er, [...] (I)
 if no heirs there are, [...]

Preposed negation is also observed in Norwegian and Swedish (Johannessen, 2000; Jensen, 2001), but with (slightly) different properties. In this paper, however, I will only discuss preposed negation in Danish.

Despite the extensive literature on negation preposed negation appears to have received little attention. It is often mentioned as a further possibility of negation-placement in Danish, but apart from the descriptive investigation in Skaftø-Jensen (1995) it does not seem to have been subject to detailed study. The paper thus addresses two fundamental questions: what is the structure and what is the semantics of preposed negation.

In line with previous analyses of finite negation in English (Kim and Sag, 2002), I will suggest that the preposed element is a sister of the complementizer and that the preposed negation is the filler of a filler-gap dependency. I will further suggest that preposed negation is associated with special discourse semantic properties. Preposed negation is associated with negation of polarity focus (“verum”-focus) of a proposition lacking a topic. This account explains the peculiar behaviour of positive and negative polarity items with preposed negation. Though being sentential negation, preposed negation does not license strong negative polarity items and it licenses strong positive polarity items. Ordinary negation on the other hand licenses strong negative polarity items and rules out strong positive polarity items, when it is not associated with polarity focus of the clause. Thus while ordinary negation can be associated with both polarity focus and VP focus, preposed negation is only associated with polarity focus and may be seen as a structural means of signaling polarity focus. At the same time the subject of a clause with preposed negation obeys certain interpretative constraints: preposed negation is preferred with non-referential subjects and with weak readings of indefinite subjects. Furthermore topic-binding particles as investigated for German in Breindl (2008) are impossible with preposed negation. The constraints on the subject of

a clause with preposed negation point to the conclusion that these clauses lack a topic, the subject being within the scope of the negation, i.e. the focal information (Ambridge and Goldberg, 2008). To account for the specific semantics of preposed negation and for the fact that only complementizers with a specific semantics and a specific phonological shape license preposing I will suggest that preposed negation is a construction, i.e. a specific pairing of syntax and semantics.

The paper is organized as follows. In Section 2 the basic properties of preposed negation are discussed. Negation will be shown to be part of a larger picture of preposing sentential adverbs and the construction will be shown to be subject to semantic as well phonological restrictions on the licensing complementizers. Section 3 deals with the structure of preposed negation. The construction is shown to be a syntactic structure and not a lexical structure or an adjunction structure as otherwise expected. In Section 4 the semantics and pragmatics of the construction are discussed. The construction is shown to be associated with negation of the polarity of a *topic-less* clause. Section 5 finally provides an analysis of the construction within the frame-work of HPSG using Minimal Recursion Semantics (MRS).

2 Preposed negation

2.1 Preposing in Non-Veridical Contexts

Preposing of the negation is only possible in embedded sentences containing a complementizer. It is most often observed in conditional clauses, but it is not restricted to conditional clauses. Preposing is possible with different kinds of non-veridical complementizers, i.e. operators that do not entail the truth of their proposition (Giannakidou, 1999; Skafte-Jensen, 1995).³ Cf.

- (5) jeg spekulerer på om ikke det er for sent
I wonder PREP whether not it is too late
- (6) mon ikke det er for sent
MON not it is too late
'don't you think it is too late'
- (7) bare ikke han kommer
BARE not he comes
'I hope he doesn't come'

In (5) preposing appears in an embedded polar question, in (6) in a deliberative question where the addressee is not supposed to know the answer to the question

³Skafte-Jensen (1995), however, gives (constructed) examples of preposing in temporal (veridical) clauses.

(Erteschik-Shir, 2009) and in (7) in an optative clause.⁴ The complementizer *at* ('that') is especially telling, since it allows both a veridical (assertive) reading and a non-veridical (intentional) reading. Preposing is only possible in the latter reading.

- (8) a. [...] og lagt albuen på pergamentet, at ikke vinden
 [...] and placed elbow.DEF on pergament.DEF that not wind.DEF
 skulle spille med det (I)
 should play with it
 'and placed the elbow on the pergament so that the wind should not play with it'
- b. * [...] og sagde, at ikke barnet skulle lege med det
 [...] and said, that not child.DEF should play with it
 'and said that the child should not play with it'

Preposing is not restricted to negation or negative quantifier phrases either. It is also observed with a wide range of (polarity-) adverbs, even with adverb phrases where a preposed adverb is further modified by other adverbs (11) (cf. also Skafte-Jensen (1995)).

- (9) hvis alligevel du deltager [...]
 if anyway you participate [...]
- (10) hvis godt du vil deltage [...]
 if AFFIRM you want to participate [...]
- (11) hvis [ADVP altså alligevel ikke] du deltager [...]
 if that.is anyway not you participate [...]
 'if you don't participate anyway, that is'

Since preposing is only possible in complementizer clauses, it is not observed in embedded constituent questions with the possible exception of *hvorfor* ('why'), where occasional examples of preposing are found, cf. (12).

- (12) [...] hvori han ligefrem spørger hvorfor ikke Musikerne
 [...] wherein he actually asks why not musicians.DEF
 benytter andre Konsonanter end Octaven [...] (I)
 use other consonants than octave.DEF

2.2 The Lexical Restriction on Preposed Negation

The fact that preposing occurs with many kinds of adverbs in all kinds of non-veridical contexts casts doubt on the claim that preposed negation is motivated by the close bond between conditional clauses and negation as claimed by Jespersen

⁴Note that *bare* ('I hope') and *mon* ('I wonder') may also occur as adverbs. Erteschik-Shir (2009) actually claims that *mon* ('I wonder') is always an adverb. I will not discuss this possibility further here, but I assume that it may be both a complementizer and an adverb.

(1917) (p. 62). But also other properties of preposed negation argue against a purely semantic account of the phenomenon. Conditional semantics is no sufficient criterion for preposing. Conditional V1-clauses do not allow preposing (contrary to e.g. Norwegian as shown in Johannessen (2000)).

- (13) får (*ikke) vi (ikke) pengene [...] (DK)
get (*not) we (not) the.money [...]

Furthermore not even all conditional complementizers allow preposing - despite their semantics. The complementizers *såfremt* ('provided that') and *ifald* ('in case') do not allow preposing, while the complementizers *hvis* ('if') and *dersom* ('if') do.

- (14) hvis / dersom ikke du vil deltage
if / if not you want to participate
- (15) * såfremt / ifald ikke du vil deltage
provided that / in case not you want to participate

The relevant generalization appears to be a phonological restriction on the complementizers that allow preposing. Only mono-syllabic complementizers and complementizers with an unstressed final syllable ('*dersom* ('if')) allow preposing. The complementizers *såfremt* and *ifald* in (15) have a stressed final syllable. Given that preposed negation is obligatorily stressed this restriction may again be seen as a general restriction against having two adjacent stressed syllables.

2.2.1 Sentential or Constituent Negation

Complementizer clauses with the word order C-Neg-Subj are (in most cases) structurally ambiguous. The negation element may either be a preposed adverbial phrase or it may be a modifier of the Subject-DP, i.e. constituent negation of the subject. Cf. the following structural bracketing (the structural representation of (17) is motivated in Section 3).

- (16) hvis [_{NP} ikke regeringen] griber ind (DK)
if not government.DEF intervenes
- (17) hvis [_{ADV}P ikke] [_{NP} regeringen] griber ind
if [[_{ADV}P] not government.DEF intervenes

However, the two structures are prosodically distinguished. Preposed negation is always stressed (Skafte-Jensen, 1995),⁵ while constituent negation is unstressed.⁶

⁵Actually Skafte-Jensen (1995) note that only adverbs capable of being stressed can participate in preposing. This excludes modal adverbs/particles like *jo* ('you know') *vist* ('presumably').

⁶Jensen (2001) (p. 132) fails to distinguish preposed negation from constituent negation. She claims that the subject is obligatorily stressed in the order C-Neg-Subj. But preposed negation is

- (18) a. hvis [NP *ikke* reGERingen] griber ind
 if not government.DEF intervenes
- b. hvis [ADVP IKKE] [NP regeringen] griber ind
 if not the.government intervenes

Another difference between the two structures in (16) is that preposed negation scopes over the whole subordinate clause and not just the subject. For that reason preposed negation cancels out ordinary negation in post-subject position. Thus preposing does indeed behave as sentential negation.⁷

- (19) hvis ikke seerne ikke var advaret → hvis seerne VAR
 if not viewers.DEF not were warned → if viewers.DEF WERE
 advaret
 warned

As expected, preposed negation like ordinary sentential negation licenses the presuppositional negative polarity adverb *heller* ('either') in the second clause.

- (20) hvis du ikke forsøger at sikre dit netværk og Peter heller ikke gør
 if you not try to secure your network and Peter either not does

Also preposed negation occurs in neg-raising environments, i.e. environments where a matrix negation scopes over an embedded clause (Horn, 1975, 1989; Sailer, 2006). Neg-raising only applies to sentential negation and not to constituent negation.

- (21) hvis ikke du tror du kan klare det → hvis du tror, du ikke
 if not you think you can manage it → if you think, you not
 kan klare det (I)
 can manage it

Thus there is very clear evidence that the word order C-Neg-Subj is structurally ambiguous and that preposed negation is different from constituent negation. Preposed negation behaves as sentential negation in crucial respects (if not in all respects as will be shown in Section 4).

also possible with DPs that cannot be stressed at all and that do not allow constituent negation since these subjects fail to meet the semantic condition of providing a contrastive reading of (contextually salient) alternative referents (Brandtler, 2006). Examples are expletives as in (i) and the pronoun *man* ('one').

- (i) a. hvis IKKE det regner
 if NOT it rains
- b. *hvis [ikke DET] regner
 if NOT it rains

⁷Also the occurrence of preposed negative quantifier phrases as in (4) above shows that we are dealing with sentential negation. Negative quantifier phrases cannot occur as constituent negation.

2.3 Negation-Preposing or Subject Lowering?

The particular word order C-Neg-Subj may arise in two ways: the negation is preposed as has been tacitly assumed in the previous discussion, or the subject is not in its canonical position outside the VP, but rather inside the VP. In both cases the negation element will precede the subject as illustrated in the figure below.

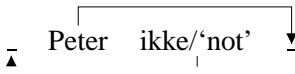
- (22) hvis/‘if’  Peter ikke/‘not’ kommer/‘comes’

To determine whether the negation is preposed or the subject is “lowered” we have to look at the distribution of other adverbs and other determiners.

As mentioned in Section 1, adverbs delimit the left-edge of the VP in embedded clauses. If the subject were inside the VP in the construction under discussion, we should expect adverbs left-adjoined to VP to precede the subject, but they do not. Adverbs occur between the subject and the finite verb also when the negation follows the complementizer, showing that the subject is still in its canonical position outside the VP. Cf.

- (23) hvis ikke radiatorer og rør [alligevel] skal renoveres [...](I)
 if not radiators and pipes anyway have.to be.renovated
 ‘if radiators and pipes don’t have to be renovated anyway’

Further evidence that negation is indeed preposed comes from the interaction with the pleonastic complementizer *at* (‘that’). In colloquial Danish *hvis* (‘if’) may co-occur with the complementizer *at* (‘that’).

- (24) hvis at jeg ikke gjorde det, ville de tvinge en overdosis i mig (I)
 if that I not did it would they force an overdose into me

If we were dealing with subject-“lowering” rather than preposing of the negation, we should expect the negation *ikke* to occur after the pleonastic complementizer *at* (‘that’) as in (25) below.

- (25) * hvis at t_i ikke [_{VP} jeg_i gjorde det], ville de [...]
 if that t_i not I_i did it would they [...]

However, as noted by Jespersen (1917) (p. 62) and also in Pedersen (2009) (p. 327) the negation element obligatorily occurs to the left of the pleonastic complementizer *at* (‘that’) as expected if the negation element is indeed preposed and the subject is in its canonical position outside the VP.

- (26) og hvis ikke at Folketinget kan stole på de oplysninger, (I)
 and if not that parliament.DEF can trust PREP the information,

To sum up the basic properties of preposed negation so far: this section has established that the construction under discussion is indeed preposing of sentential negation which is lexically restricted to non-veridical complementizers with a

certain phonological shape. They must be mono-syllabic or contain an unstressed final syllable. The next section will investigate the syntactic structure of preposed negation.

3 The Structure of Preposed Negation

In this section I turn to the structural analysis of preposed negation. Preposed negation appears adjacent to the complementizer (Pedersen, 2009) and it is semantically and lexically licensed by the complementizer as shown in Section 2. This pattern may imply three things: the complementizer and the preposed negation form a kind of composite complementizer, the negation cliticizes to the complementizer (Johannessen, 2000) or the complementizer and the negation is a lexicalized collocation as suggested by Pedersen (2009). Support for these structural possibilities comes from the fact that negation in some languages surfaces as a lexical element in the syntax (a non-projection word), i.e. the negation does not project a syntactic phrase as claimed for Swedish in Toivonen (2003). I will, however, conclude that preposed negation can indeed be syntactically complex and that a lexical analysis or an analysis as a clitic is untenable. Secondly I show that preposed negation cannot be analysed as either adjunction to C or the following S. Instead I will argue that preposed negation is a daughter of CP and that the negation element or the negative quantifier phrase is extracted from the following S. This allows for two possible analyses of preposed negation as either a complement of the complementizer (as claimed for finite English negation in Kim and Sag (2002)) or as a special construction. Given the particular semantics of preposed negation discussed in Section 4. I will argue that it constitutes a special construction.

3.1 Preposed Negation as a Lexical Structure

A first hypothesis is that preposed negation is part of a lexical structure, i.e. that the negation and the complementizer form a kind of composite complementizer even though complementizers are traditionally assumed to form a closed word class. But if preposed negation is the result of a lexical process we should expect it to be an operation on lexical items and we should expect it to obey blocking-constraints such that existing words block the formation of words with the same semantics.

Preposed negation cannot be the output of a lexical process given that the negation element can also be a syntactic phrase not available for further lexical processes. The negation element may contain (negative polarity) degree words such as *slet* ('at all') (cf. (27)) and it can also be a negative quantifier phrase (a DP or an NP) with prenominal modification, cf. (28). Thus the negation in Danish is a projecting word as opposed to the analysis of negation in Swedish in Toivonen (2003).

- (27) Hvis slet ikke der står noget
if at.all not it says anything

- (28) hvis [ingen (direkte) arvinger] der er
 if no (direct) heirs there are

The possibility of preposed quantifier phrases also argue against a purely collocational analysis as suggested in (Pedersen, 2009) since such quantifier phrases are productively formed and hardly count as collocational constructs.

Furthermore a composite complementizer consisting of *hvis* ('if') and *ikke* ('not') ought to be blocked by the presence of the complementizer *medmindre* ('unless') which lexicalizes conditional semantics taking scope over negation. The fact that it is not blocked suggests that preposed negation is a syntactic formation. Thus I conclude that preposed negation is indeed a phenomenon to be dealt with in the syntax.

3.2 The Syntax of Preposed Negation

Preposed negation is a syntactic phrase but where does it attach structurally? Is it a modifier of the following S or is it a modifier of the preceding C? I will discuss both possibilities in turn and conclude that the data argue against both possibilities.

Johannessen (2000) (p. 14) suggests that preposed negation in Norwegian is adjoined to C as shown in (29) below.

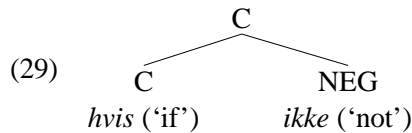

In fact Johannessen (2000) suggests that preposed negation cliticizes to C, but as already shown in (27) and (4) above, preposed negation in Danish can be syntactically complex and hence cannot be a clitic. Alternatively the negation phrase is a modifier of the complementizer so that the structure in (29) is a modificational adjunction structure. The problem with this analysis is that the negation is within the scope of the complementizer. Conditional semantics always takes scope over the negation element giving the following interpretation: IF(NOT(p)). This is unexpected if the negation is a modifier of the complementizer, since the modifier is otherwise assumed to take scope over the modified head in modificational structures. Thus an analysis as modificational adjunction to C is at odds with the semantic composition of the structure.

Another possibility is that preposed negation left-adjoints to the following S yielding the structure shown in (30) below.

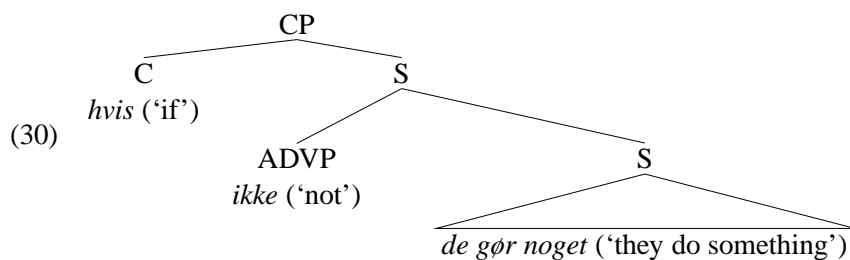

A first problem is that the structure in (30) obscures the fact that there is a close dependency between the complementizer and the preposed negation: they must be adjacent and preposing is lexically restricted (cf. Section 2.2). If the negation adjoins to the following S it is difficult to state that adjunction to S is only possible if the negation is preceded by a complementizer⁸ with a particular semantics and a particular phonological shape. But there is also other evidence that (30) cannot be the right structure. If the negation is allowed to left-adjoin to S, we should expect it also to be able to left-adjoin to the second conjunct of two coordinated Ss occurring with the right kind of complementizer. But this appears to be marginal at best. Cf.

- (31) ??/* *hvis* [_S *ikke Peter vil*] og [_S *ikke Louise er syg*]
 if not Peter will and not Louise is ill

In addition preposed negation may be stranded in ellipsis. This is unexpected under the adjunction analysis since there is no S for the negation element to adjoin to as also noted for English in Kim and Sag (2002).

- (32) [*Hvis ikke*], er det *ikke ulovligt* at have dem stående (DK)
 If not is it not illegal to have them around

The ellipsis data in (32) and the fact that the negation only marginally can show up before the second conjunct of a coordination as in (31) is expected if the negation element does not adjoin to the following S but if it is a daughter of CP. Thus I conclude that preposed negation is a daughter of CP as shown in (33) below.

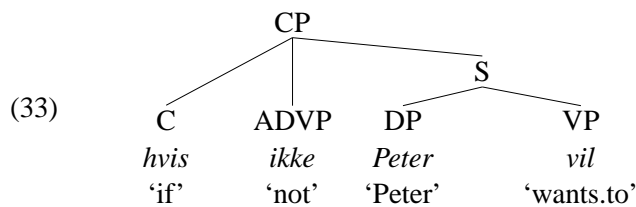

However, this analysis makes preposed negation remarkably different from ordinary negation. Ordinary negation is adjoined to VP and does not occur as a daughter of CP. Ordinary negation occurs in adjunction position to the left of the verbal head, it can be separated from the verbal head by other adjuncts and it may occur adjoined to the second VP-conjunct of a coordination.

- (34) *fordi han* [*ikke ser* *filmen*]
 because he not sees movie.DEF

⁸Negation adjoining to an S is otherwise only possible in so-called metanegation (Horn, 1989; Christensen, 2005). Negation adjoins to an (initial or parenthetical) unembedded complementizer clause with the complementizer *at* ('that') or *fordi* ('because') and serves to deny an otherwise invited (conversational) implicature.

- (i) *ikke at jeg frygter for hun bliver sur, men jeg er bange for ...*
 not that I am afraid PREP she gets angry, but I am afraid PREP...

- (35) fordi de [ikke {som raske mennesker} {hurtigt} er
 because they not such as healthy people quickly are
 i stand til at slukke ilden]
 capable of extinguishing fire.DEF (DK)
- (36) fordi han ikke læser avis og [ikke ser fjernsyn]
 because he not reads newspaper and not watches television

Thus it appears that we would have very different analyses of ordinary negation and preposed negation. In addition we have not yet accounted for preposing of negative quantifier phrases. Negative quantifier phrases are part of a filler-gap dependency given that the preposed phrase must be identified with a complement gap to the right of the main verb. Cf.

- (37) hvis du ingen børn_i har _{-i}
 if you no children have
- (38) hvis ingen børn_i du _{-i} har _{-i}
 if no children you have

The preposed phrase *ingen børn* ('no kids') is not just an adjunct but must be associated with the object of the verb *har* ('has'). Pursuing a unified analysis of preposing, it thus appears to be the case that not only preposed quantifier phrases but also the preposed negation is a filler. The advantage of this analysis is that ordinary negation as well as negative quantifier phrases adjoin to the VP and both kinds of negative constituents may be dislocated to the left of the complementizer given the right kind of complementizer. The analysis of preposing as a filler-gap dependency allows for a unified analysis of negation and negative quantifier phrases.⁹ Cf. the following representation.

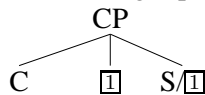

Thus the conclusion of this section is that preposing is a filler-gap dependency where a complementizer selects an S with a slashed constituent and allows this element to surface as a kind of complement of the complementizer.¹⁰

⁹The ellipsis data shown in (32) may, however, be problematic for this analysis of the preposed negation element as extraction. In elliptical structures the gap of the negation is elided while the filler is still there. While elision of a clause from which an argument has been extracted appears to be marginal, elision is much better if the extracted element is an adjunct.

- (i) ??/* Peter tror Poul bliver løsladt i morgen. Hvem tror han?
 Peter thinks book.DEF is released tomorrow. Who thinks he?
- (ii) Peter tror Poul bliver løsladt i morgen. Hvornår tror han?
 Peter thinks Poul is released tomorrow. When thinks he?

Thus it appears that the extraction site of adjuncts can be elided and preposed negation and preposed quantifier phrases positionally behave as adjuncts.

¹⁰A problem for the analysis as extraction is that preposed negation does not seem to obey "Across-the-Board"-constraints otherwise observed in coordination from which a constituent is extracted.

4 Preposed Negation as *verum*-Negation

Having discussed the basic properties and the syntax of preposed negation, a second question arises: why does the syntax of Danish allow for this additional placement of the negation element? Two factors appear to be crucial to the understanding of preposing: the behaviour of (strong) negative polarity (NPI) items and the interpretation of (indefinite) subjects with preposed negation. In this section I will show that the behaviour of polarity items (PI) point to the conclusion that preposed negation is associated with VERUM-negation (in the sense of Höhle (1992)). Furthermore I will show that preposed negation is associated with an *all_comment* information structure, i.e. a clause lacking an (aboutness-) TOPIC.

4.1 The Behaviour of Strong Polarity Items

As observed in Section 2 preposed negation behaves like (ordinary) sentential negation in crucial respects. However, preposed negation shows a totally different behaviour wrt. strong polarity items. Strong polarity items (either positive or negative) are sensitive to *antiveridical* contexts (Giannakidou, 1999): strong negative PIs are licensed by negation (or negative elements), strong positive PIs are ruled out by negation. Weak PIs on the other hand are licensed in *non-veridical* contexts (Giannakidou, 1999) and may thus occur independently in conditional clauses. Weak PIs are therefore expected to occur with preposed negation, given that also preposed negation is licensed in non-veridical contexts (cf. Section 2). Example (39) shows that the weak PI *nogensinde* ('ever') can also occur in an unnegated conditional clause.

- (39) Hvis (ikke) du nogensinde har oplevet mursten, stålplader og
if not you ever have seen bricks steel plates and
jernstænger blive slået igennem med panden (I)
iron sticks be cut through with forehead.DEF

Strong NPIs, however, are licensed in conditional clauses by ordinary negation, but they are marginal at best with preposed negation. In (40a) ordinary negation licenses the polarity item *en rød øre* ('a red cent'). Example (40b) is marginal. As one informant put it: it sounds as if you expect the users to pay a red cent, which is nonsense. Thus it seems that preposed negation is too weak to license strong NPIs.

Given ATB-constraints on coordination a preposed negation ought to have scope over both conjuncts always. While this is indeed possible, preposed negation does not have to have scope over the second conjunct. Thus the following examples allows for two readings: $\neg(p \vee q)$ and $\neg p \vee q$.

- (i) hvis ikke CDU går tilbage og FDP gå frem
if not CDU goes back and FDP goes forward
'if not CDU loses votes and FDP gains votes'

- (40) a. hvis brugerne ikke skal lægge *en rød øre*, når de stiger på(I)
 if users.DEF not must pay a red cent, when they enter PREP
 b. ?? *hvis ikke* brugerne skal lægge *en rød øre*, når de stiger på
 if not users.DEF must pay a red cent, when they enter PREP

In a similar vein preposed negation is also too weak to rule out strong positive PIs. The underlined strong positive PI in (41a) – a somewhat outdated expression meaning “to be a top-professional” – cannot occur in a conditional clause with ordinary negation, However it is much better with preposed negation as in (41b).

- (41) a. ??/* hvis du bare ikke *kan det pis*, skal du lade være
 if you just not can that stuff, don't do it
 ‘if you are not a top-professional, then don't do it’
 b. hvis ikke du bare *kan det pis*, skal du lade være
 if not you just can that stuff, don't do it
 ‘if you are not a top-professional, then don't do it’

On the account of PIs in Giannakidou (1999), NPIs are licensed when they are in the immediate scope of an anti-veridical operator such as *ikke* (‘not’). Thus it appears that NPIs in clauses with preposed negation are not in the immediate scope of the negation. This failure to license strong polarity items is also observed with negated VERUM-focus, i.e. when a finite verb within the scope of ordinary negation is stressed (Höhle, 1992).¹¹

- (42) ??/* brugerne GIVER ikke en rød øre
 users.DEF give not a red cent
 ‘it isn't the case, that the users give a red cent’

Negation focus, on the other hand, i.e. stress on the negation element, does license negative polarity items, arguing against an analysis of preposed negation as involving negation focus, despite the fact, that the negation is stressed.

- (43) brugerne giver IKKE en rød øre
 users.DEF give ikke a red cent
 ‘the users really don't give a red cent’

Following this reasoning it appears that preposed negation is associated with negated VERUM-focus. The additional VERUM-predicate *it is the case that* (Höhle, 1992) thus may explain the peculiar behaviour of the strong PIs. Negation of the predicate *it is the case* does not license NPIs (Gajewski, 2007; Horn, 1989; van der Wouden, 1997). Thus, it appears that ordinary negation (without VERUM-focus)

¹¹The verb in (42) is within the scope of negation given that the verb in V1/V2-clauses is associated with its canonical position to the right of the negation as observed in non-V1/V2-clauses. I assume that it is associated with a trace as in the analysis of V1 and V2 in German in Müller (2008) (chap. 9).

gives rise to the paraphrase in (44), while preposed negation gives rise to the paraphrase in (45).

- (44) hvis brugerne ikke skal lægge en rød øre ...
 if users.DEF not have.to pay a red cent ...
 ⇒ if the users do not have to pay a red cent. . .
- (45) ?? hvis ikke brugerne skal lægge en rød øre ...
 if not users.DEF have.to pay a red cent ...
 ⇒ if *it is not the case* that the users have to pay a red cent. . .

As the paraphrases make clear, VERUM embeds a positive proposition, thus explaining the impossibility of negative PIs and the possibility of positive PIs. Preposed negation introduces a VERUM-predicate within its scope. With preposed negation the polarity of the conditional clause is negated, not the proposition as such.

4.2 The Information Structure of Preposing

But what distinguishes ordinary negation with VERUM-focus from preposed negation, if preposed negation is also associated with VERUM-focus? Preposed negation is associated with an embedded clause with a particular information structure. Where embedded clauses with ordinary negation are associated with a basic *topic_comment*-articulation, clauses with preposed negation are characterized by the absence of a TOPIC. Clauses with preposed negation do not have an (aboutness-) TOPIC in the sense of Krifka (2007). Evidence comes from the use of non-referential subjects, the interpretation of indefinite subjects and the use of TOPIC-binding particles.

Preposed negation is preferred with non-referential subjects such as *enhver* ('everybody') and *alle* ('everyone').¹² Cf.

- (46) Men hvis ikke enhver skulle blive depri af denne elendige
 but if not everyone should get depressed by this horrible
 sommer [...] (I)
 summer [...]
- (47) ?? Men hvis enhver ikke skulle blive depri af denne elendige
 but if everyone not should get depressed by this horrible
 sommer [...] (I)
 summer [...]

Indefinite pronouns like *enhver* ('everybody') are non-referential and since an (aboutness-) TOPIC presupposes referentiality, indefinite pronouns are degraded as TOPICS (Pittner, 2004; Frey, 2004). The preference of preposed negation with

¹²This observation is due to Line Mikkelsen (p.c.).

non-referential pronouns thus receives a straight-forward explanation, if preposing is associated with the lack of a topic.

Also the interpretation of indefinite subjects point to the conclusion that clauses with preposed negation have no TOPIC. Following Diesing (1992) indefinite NPs exhibit either a weak (existential) reading or a strong (generic or proportional) reading. The weak reading is typical of non-topicality, while the strong reading is typical of topicality (Diesing, 1992). Preposed negation does indeed favour the weak reading of indefinites again suggesting that the subject is no TOPIC. Cf. (48) where the indefinite subject has an existential reading.

- (48) han ville uden tvivl have slået sig ihjel, hvis ikke [en rotte] i det
 he would beyond doubt have been killed if not a rat in that
 samme var kommet løbende hen over gulvet (DK)
 moment had come running across floor.DEF

Ordinary negation in turn favours a strong reading of indefinites as expected if the subject is a TOPIC. In (49) the indefinite is associated with a generic reading.

- (49) Hvis [en atlet] ikke vil eller glemmer at fortælle Anti-Doping
 If [an athlete] not will or forgets to tell Anti-Doping
 Danmark, [...] (DK)
 Denmark [...]

This analysis of the information structure of preposing is further reinforced by the behaviour of TOPIC-binding particles. TOPIC-binding particles are particles indicating TOPIC-shift or TOPIC-continuation (Breindl, 2008). A particle such as *derimod* ('in contrast') can attach to a subject NP of either a V2-clause or a non-V2-clause¹³ to indicate a TOPIC-shift as shown in (50). In conditional clauses TOPIC-binding particles are fine with ordinary negation (51), but highly degraded with preposed negation (52), since there is no TOPIC to bind.

- (50) men at derimod stress ser ud til at være synderen (I)
 but that in contrast stress appears to be sinner.DEF
- (51) Hvis derimod lønstigningerne ikke tager af (I)
 if in contrast wages rising.DEF not reduce
- (52) ?? Hvis ikke derimod lønstigningerne tager af
 if not in contrast wages rising.DEF reduce

On the evidence presented in this section preposed negation is used to negate the VERUM of an *all_comment* clause, i.e. a clause lacking a TOPIC.

¹³In V2-clauses the particle occurs to the right of the subject in the so-called *Nacherstposition* (Breindl, 2008).

- (i) Regeringen derimod prøver at få danskerne til at arbejde mere (I)
 government.DEF in contrast tries to make danes.DEF PREP to work more

5 An HPSG Approach

The crucial argument for positing a construction for preposed negation is that it is associated with a particular semantics. Preposed negation is associated with negated *verum* focus, thus the construction itself introduces a *verum* predicate which in turn is within the scope of negation. Cf. the examples below.

- (53) a. hvis Peter ikke vinder
 if Peter not wins
 CONDITIONAL > NEGATION > PROPOSITION
- b. hvis ikke Peter vinder
 if not Peter wins
 CONDITIONAL > NEGATION > VERUM > PROPOSITION

In Minimal Recursion Semantics the semantic representation is given as a bag of basic relations (RELS) which in turn are connected by means of labels giving the functor-argument relationships holding between the individual predicates (LBL and ARGn). Scopal relationships between the individual relations are indicated by so-called *qeq*-constraints (*equality modulo quantifiers*) in the feature H_CONS. An argument position which is *qeq*-related to a label does not have to be filled by that label. The argument position can be filled by another label which in turn has the first label as an argument. Thus other scopal elements can intervene between two elements, where the first outscopes the other (Copestake et al., 2005) (p. 297). The lexical entry for the complementizer *hvis* ('if') is given below.

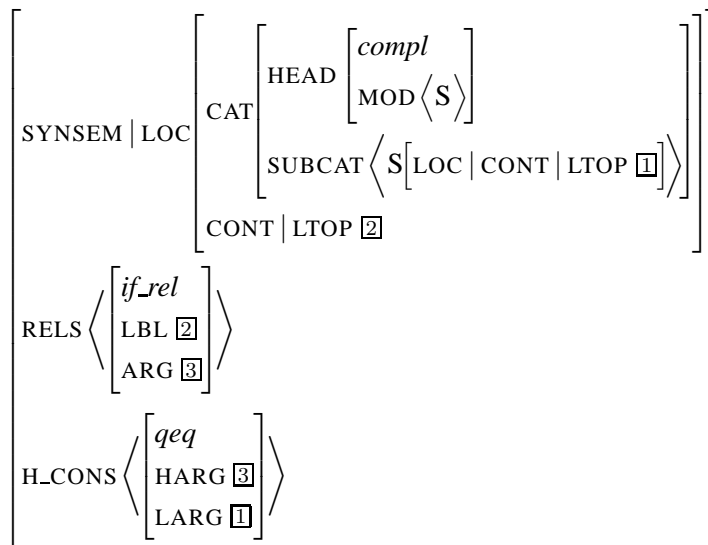

The complementizer selects its clause through the feature SUBCAT. The complementizer introduces the basic predicate *if_rel* and the conditional semantics takes as its argument the subcategorized S or a quantifier outscoping the subcategorized S as guaranteed by the *qeq*-constraint in H_CONS. This is crucial in accounting for preposed negative quantifier phrases. The entry for the negation is given below.

The negation selects its modified VP through the feature MOD. The negation introduces the basic relation *neg_rel* taking as its argument the modified VP modulo intervening quantifiers.

$$\left[\begin{array}{l} \text{SYNSEM} \mid \text{LOC} \left[\begin{array}{l} \text{CAT} \mid \text{HEAD} \mid \text{MOD} \langle \text{VP}[\text{LOC} \mid \text{CONT} \mid \text{LTOP } \boxed{1}] \rangle \\ \text{CONT} \mid \text{LTOP } \boxed{2} \end{array} \right] \\ \text{RELS} \langle \left[\begin{array}{l} \textit{neg_rel} \\ \text{LBL } \boxed{2} \\ \text{ARG } \boxed{3} \end{array} \right] \rangle \\ \text{H_CONS} \langle \left[\begin{array}{l} \textit{qeq} \\ \text{HARG } \boxed{3} \\ \text{LARG } \boxed{1} \end{array} \right] \rangle \end{array} \right]$$

Consider next the construction for preposed negation.

$$\left[\begin{array}{l} \text{SYNSEM} \left[\begin{array}{l} \text{LOC} \mid \text{CAT} \left[\begin{array}{l} \text{HEAD } \boxed{1} \\ \text{SPR} \langle \rangle \\ \text{SUBCAT} \langle \rangle \end{array} \right] \\ \text{NONLOC} \mid \text{INHER} \left[\begin{array}{l} \text{REL} \langle \rangle \\ \text{SLASH} \langle \rangle \end{array} \right] \end{array} \right] \\ \text{C_CONT} \left[\begin{array}{l} \text{HOOK } \boxed{2} \\ \text{RELS} \langle \left[\begin{array}{l} \textit{verum_rel} \\ \text{LBL } \boxed{3} \\ \text{ARG } \boxed{4} \end{array} \right] \rangle \\ \text{H_CONS} \langle \left[\begin{array}{l} \textit{qeq} \\ \text{HARG } \boxed{5} \\ \text{LARG } \boxed{6} \end{array} \right], \left[\begin{array}{l} \textit{qeq} \\ \text{HARG } \boxed{7} \\ \text{LARG } \boxed{3} \end{array} \right], \left[\begin{array}{l} \textit{qeq} \\ \text{HARG } \boxed{4} \\ \text{LARG } \boxed{8} \end{array} \right] \rangle \end{array} \right] \\ \text{NH-DTRS} \langle \left[\begin{array}{l} \text{SYNSEM} \mid \text{LOC} \left[\begin{array}{l} \text{CAT} \left[\begin{array}{l} \text{HEAD } \boxed{1} \textit{compl} \\ \text{SUBCAT} \langle \boxed{9} \rangle \end{array} \right] \\ \text{CONT } \boxed{2} \end{array} \right] \\ \text{RELS} \langle \left[\begin{array}{l} \textit{non_veridical} \\ \text{ARG1 } \boxed{5} \end{array} \right] \rangle \end{array} \right], \left[\begin{array}{l} \text{SYNSEM} \mid \text{LOC } \boxed{10} \\ \text{RELS} \langle \left[\begin{array}{l} \textit{neg_rel} \\ \text{LBL } \boxed{6} \\ \text{ARG } \boxed{7} \end{array} \right] \rangle \oplus \textit{list} \end{array} \right] \rangle \\ \left[\begin{array}{l} \text{SYNSEM } \boxed{9} \left[\begin{array}{l} \text{LOC} \mid \text{CONT} \mid \text{KEY} \mid \text{LBL } \boxed{8} \\ \text{NONLOC} \mid \text{INHER} \mid \text{SLASH} \langle \boxed{10} \rangle \end{array} \right] \end{array} \right]$$

The construction for preposed negation defines three daughters: the complementizer, the negation and the clause. The first daughter is the head of the construction

and it is constrained to be a non-veridical complementizer subcategorizing for the third daughter (the clause). The second daughter is constrained to be negated (it contains the negation relation as the first of its basic relations). This semantic constraint ensures that not only the negation *ikke* ('not') but also negated quantifier phrases can be preposed. The second daughter is the filler of the gap associated with the third daughter (the LOC(al) value of the second daughter is structure-shared with the SLASH-value of the third daughter), ensuring that negative preposed quantifier phrases are analyzed as complements of the verb. The motivation for positing a separate construction is given in the constructional content (C_CONT). The construction introduces the basic *verum*-relation which has the proposition in its scope. The scoping constraints in H_CONS state that the complementizer out_scopes the negation, that the negation outscopes the *verum*-relation and that the *verum*-relation outscopes the proposition. These constraints give the scoping relationships shown in (53b). The semantic representation for the whole construction is constrained by an independent semantics principle to be the union of the RELS and H_CONS of the daughters.

6 Conclusion

The paper has provided an analysis of preposed negation in Danish uncovering a host of properties that appear to have gone unnoticed in the literature. It is proposed that preposed negation is associated with negated *verum*-focus of a proposition lacking a topic and it has been argued that this should be analyzed as a construction given that this semantics is not associated with a particular lexical entry but with a specific ordering of existing lexical entries. The analysis has been formalized in construction-based HPSG and it has been implemented¹⁴ in the TRALE system (Meurers et al., 2002; Penn, 2004; Müller, 2007) as part of a grammar fragment of Danish which uses a core grammar for German, Persian, Mandarin Chinese and Maltese. The respective grammars can be downloaded at URL: <http://hpsg.fu-berlin.de/Software/>.

References

- Ambridge, Ben and Goldberg, Adele E. 2008. The island status of clausal complements: Evidence in favor of an information structure explanation. *Cognitive Linguistics* 19(3), 357–389.
- Brandtler, Johan. 2006. On Aristotle and Baldness - Topic, Reference, Presupposition of Existence, and Negation. *Working Papers in Scandinavian Syntax* 77, 177–204.

¹⁴The implementation is due to Stefan Müller.

- Breindl, Eva. 2008. Die Brigitte nun kann der Hans nicht ausstehen. Gebundene Topiks im Deutschen. *Deutsche Sprache* 01, 27–49.
- Christensen, Ken Ramshøj. 2005. *Interfaces: Negation - Syntax - Brain*. Ph. D.thesis, University of Aarhus.
- Copestake, Ann, Flickinger, Dan, Pollard, Carl and Sag, Ivan A. 2005. Minimal Recursion Semantics. *Research on Language and Computation* 3, 281–332.
- Diesing, Molly. 1992. *Indefinites*, volume 20 of *Linguistic Inquiries Monograph*. MIT Press.
- Erteschik-Shir, Nomi. 2009. The Phonology of adverb placement, Object Shift and V-2; the case of Danish ‘MON’.
- Frey, Werner. 2004. A Medial Topic Position for German. *Linguistische Berichte* 198.
- Gajewski, Jan. 2007. Neg-Raising and Polarity. *Linguistics and Philosophy* 30, 289–328.
- Giannakidou, Anastasia. 1999. Affective Dependencies. *Linguistics and Philosophy* 22(4), 367–421.
- Höhle, Tilman N. 1992. Über Verum-Fokus im Deutschen. In Joachim Jacobs (ed.), *Informationsstruktur und Grammatik*, volume 4 of *Linguistische Berichte*, pages 112–142, Westdeutscher Verlag.
- Horn, Laurence R. 1989. *A Natural History of Negation*, volume 20. The University of Chicago Press.
- Horn, L.R. 1975. Neg-raising predicates: Toward an explanation. In *CLS*, volume 11, pages 279–294.
- Jensen, Britta. 2001. On sentential negation in the Mainland Scandinavian languages. In Maria Liakata, Britta Jensen and Didier Maillat (eds.), *Oxford University Working Papers in Linguistics, Philology and Phonetics*, volume 6, pages 115–137.
- Jespersen, Otto. 1917. *Negation in English and other languages*, volume I,5 of *Det Kgl. Danske Videnskabernes Selskab. Historisk-filologiske Meddelelser*. Høst & Søn.
- Johannessen, Janne Bondi. 2000. *Negasjonen ikke: kategori og syntaktisk posisjon*, tekstlaboratoriet, Universitetet i Oslo.
- Kim, Jong-Bok and Sag, Ivan A. 2002. Negation without Head-Movement. *Natural Language and Linguistic Theory* 20(2), 339–412.

- Krifka, Manfred. 2007. Basic notions of Information Structure. In C. Féry et al. (ed.), *The notions of information structure. Interdisciplinary Studies on Information Structure*, volume 6 of *ISIS*, Potsdam: Universitätsverlag Potsdam.
- Meurers, Walt Detmar, Penn, Gerald and Richter, Frank. 2002. A Web-Based Instructional Platform for Constraint-Based Grammar Formalisms and Parsing. In Dragomir Radev and Chris Brew (eds.), *Effective Tools and Methodologies for Teaching NLP and CL*, pages 18–25, proceedings of the Workshop held at 40th Annual Meeting of the Association for Computational Linguistics. Philadelphia, PA.
- Müller, Stefan. 2007. The Grammix CD Rom. A Software Collection for Developing Typed Feature Structure Grammars. In Tracy Holloway King and Emily M. Bender (eds.), *Grammar Engineering across Frameworks 2007*, Studies in Computational Linguistics ONLINE.
- Müller, Stefan. 2008. *Head-Driven Phrase Structure Grammar – Eine Einführung*. Stauffenberg, second edition.
- Pedersen, Karen Margrethe. 2009. Indre *at* i danske dialekter. In Rita Therkelsen and Eva Skafte Jensen (eds.), *Dramatikken i Grammatikken*, pages 321–333, Roskilde Universitet.
- Penn, Gerald. 2004. Balancing Clarity and Efficiency in Typed Feature Logic Through Delaying. In *Proceedings of the 42nd Meeting of the Association for Computational Linguistics (ACL'04), Main Volume*, pages 239–246, Barcelona, Spain.
- Pittner, Karin. 2004. Where syntax and semantics meet: adverbial positions in the German middle field. In Jennifer R. Sutin, Stefan Engelberg and Gisa Rauh (eds.), *Adverbials: The interplay between meaning, context and syntactic structure*, volume 70 of *Linguistics Aktuell*, pages 253–288, Amsterdam/Philadelphia: John Benjamins.
- Sailer, Manfred. 2006. *Don't believe* in Underspecified Semantics. In O. Bonami and P. Cabredo Hofherr (eds.), *Empirical Issues in Syntax and Semantics*, volume 6, pages 375–403.
- Skafte-Jensen, Eva. 1995. Neksusadverbialets placering i ledsætninger. *NyS* 20, 77–90.
- Toivonen, Ida. 2003. *Non-Projecting Words. A Case Study of Swedish Particles*. Dordrecht: Kluwer.
- van der Wouden, Ton. 1997. *Negative Contexts - Collocation, polarity and multiple negation*. Routledge Studies in Germanic Linguistics, Routledge: London, New York.