

An HPSG Analysis of Persian Relative Clauses

Mehran A Taghvaipour

University of Essex

Proceedings of the HPSG04 Conference

Center for Computational Linguistics

Katholieke Universiteit Leuven

Stephan Müller (Editor)

2004

CLSI Publications

<http://csli-publications.stanford.edu/>

Abstract

Relative clauses (RCs) in Persian are head-modifying constituents, all typically introduced by the invariant complementizer *ke*. Persian RCs are Unbounded Dependency Constructions (UDCs), containing either a gap or a resumptive pronoun (RP). In some positions only gaps are allowed, and in other positions only RPs. There are also some positions where both gaps and RPs are alternatively allowed. Illustrating the striking similarities between Persian gaps and RPs, I will provide an HPSG unified approach to take care of the dependency between the licensing structure and the gap/RP with a single mechanism, using only the SLASH feature. Similar to Pollard and Sag's (1994) approach to the bottom of the dependency, I will assume a special *sign* at the bottom. However, my *sign* may have a nonempty PHON value. I will introduce a feature called GAPTYPE which is a NONLOCAL feature whose value can be either *trace* or *rp*. I will introduce two constraints to capture the pattern of distribution of RPs and traces. At the top of the dependency, I will bind the nonempty SLASH at the complementizer point. I will propose a lexical entry for the complementizer *ke* that will account for the binding of SLASH by the feature BIND, which has a non-empty set as value.¹

1 Introduction

This paper presents an analysis for Persian restrictive relative clauses (RCs) in the Head-driven Phrase Structure Grammar (HPSG) framework. I will first provide some data and outline some general properties of the language, with a particular emphasis on RCs, and resumptive pronouns (RPs), their pattern of distribution, and their similarity with gaps in RC constructions. In Section 3, I will present my own analysis, which utilises only the SLASH feature (as opposed to Vaillette (2001), who uses two different NONLOCAL features). At the bottom of the dependency, I will assume a special *sign* that has a nonempty value for the SLASH feature. This special *sign* can be either a RP or a trace. I will introduce a feature called GAPTYPE which is a NONLOCAL feature whose value can be either *trace* or *rp*. I will introduce two constraints to capture the pattern of distribution of RPs and traces. At the top of the dependency, I will bind the non-empty SLASH at the complementizer point. I will propose a lexical entry for the complementizer *ke* that will account for the binding of SLASH by the feature BIND, which has a non-empty set as its value. Section 4 highlights some issues for further research and suggests some alternative approaches to the present analysis.

2 The Data

Persian is a null-subject verb-final language with SOV word order in declarative sentences and subordinate clauses. Example (1) represents a simple sentence in Persian.

¹ I am grateful to my supervisor, Bob Borsley, and two anonymous reviewers of HPSG 2004 for their constructive comments on an earlier version of this paper. I would also like to thank the audience of HPSG 2004.

(1)
 (mæn) ye doxtær daræm.
 (I) one daughter have-PRES-1sg
 ‘I have a daughter.’

Example (2) is another Persian sentence, containing a restrictive RC. Restrictive RCs in Persian are distinguished from their non-restrictive counterparts by comma intonation and the suffix *-i*, henceforth shown by *-RES* in gloss.

(2)
 zæn-i [ke mæn dust+daræm] inja nist.
 woman-RES COMP I like-PRES-1sg here NEG-
 be-3sg
 ‘The woman that I love is not here.’

Persian RCs are typically introduced by the complementizer *ke*. Ungrammatical example (3) illustrates that Persian does not allow *ke*-less RCs. This is unlike English, for example, which allows *that*-less relatives. See the English translation of (3).

(3)
 *zæn-i [Ø mæn dust+daræm] inja nist.
 woman-RES Ø I like-PRES-1sg here NEG-be-3sg
 ‘The woman I love is not here.’

The complementizer *ke* in Persian is invariant. That is, it does not agree with the noun (phrase) it follows. *Ke* is used regardless of the animacy, gender, function, or number of the noun modified by the RC. Examples in (4) illustrate invariant *ke* when the modified noun is in subject and object positions or in genitive case.

- (4)
- a. (relativized element in subject position)
- ... mærd-i ke shoma ra did...
 ...man-RES COMP you RA see-PAST-3sg
 ‘...the man who saw you...’
- b. (relativized element in object position)
- ... mærd-i ke shoma didid...
 ...man-RES COMP you see-PAST-3sg
 ‘...the man whom you saw...’

- c. (relativized element in genitive case)
 ... *mærd-i ke pirahænæš zærd æst ...*
 ...man-RES COMP shirt-his yellow be-PRES-3sg
 ...the man whose shirt is yellow ...

Personal pronouns can be used resumptively in Persian. That is, a personal pronoun is used where a gap might be expected. Example (5b) represents a Persian RC in which the pronoun *u*, ‘s/he’, is used resumptively.

- (5a)
mærd-i [ke ____ diruz molaqat kærdid] aqay-e Bayat bud.
 man-RES COMP Ø yesterday meet-PAST-2pl Mr. Bayat be-PAST-3sg
 ‘The man whom you met yesterday was Mr. Bayat.’

- (5b)
mærd-i [ke u ra² diruz molaqat kærdid] aqay-e Bayat bud.
 man-RES COMP he RA yesterday meet-PAST-2pl Mr. Bayat be-PAST-3sg
 ‘The man whom you met (*him) yesterday was Mr. Bayat.’

Table 1 below shows the pattern of distribution of gaps and resumptive pronouns in Persian restrictive RCs. In some positions, only gaps are allowed. In other positions only resumptive pronouns are allowed. Both gaps and resumptive pronouns are possible in some other positions.

	Restrictive RCs			
	Subject	Direct Object	Genitive	Object of Prep.
Gap is allowed?	Yes	Yes	No	No
RP is Allowed?	No	Yes	Yes	Yes

TABLE 1: DISTRIBUTION OF GAPS AND RPs IN RESTRICTIVE RCs

As shown in Table 1, if the relativized position is subject, a resumptive pronoun cannot appear. Examples in (6) illustrate.

- (6a)
mærd-i ke ____ pirahæn-e zærd pušideh-æst
 man-RES COMP ____ shirt-EZ yellow wear-PRESPART-3sg
 ‘The man who is wearing a yellow shirt...’

² This particle (whose colloquial form is *ro*) is a specificity marker in Persian and is shown, henceforth, by RA in gloss. For detail discussion, see Karimi (1990) and Dabirmoghaddam (1990).

(6b)

**mærd-i ke u pirahæn-e zærd pušideh æst*
man-RES COMP he shirt-EZ yellow wear-PRESPART-3sg
'The man who he is wearing a yellow shirt ...'

It is noteworthy, however, that some languages, e.g. Irish, only exclude resumptive pronouns from the highest subject position. They can freely appear in the subject position of embedded clauses. Example (7) represents an ungrammatical Irish sentence. Like (6b), the subject position in (7) is occupied by a resumptive pronoun and therefore the result is ungrammatical. Persian and Irish behave similarly here.

(7)

**an fear a raibh sé breoite*
the man COMP be-PAST he ill
'the man that (he) was ill'

(McCloskey, 1990)

However, unlike the similar behaviour of Irish and Persian in the highest subject position, the two languages behave differently in embedded positions. Examples in (8), from (McCloskey, 1990), represent clauses containing embedded subjects in Persian and Irish, respectively. There is no difference in Persian if the subject is in embedded position. Simply, resumptive pronouns are not allowed in subject positions in Persian.

(8)

a.

**adres-i [ke mæn be doktor-i [ke u æli ra*
address-RES COMP I to doctor-RES COMP he Ali RA

æmæel kærd dadæm qæælæt bud.]]
operation-PAST-3sg do-give-PAST-1sg wrong be-PAST-3sg

'The address that I gave to the doctor who (he) did an operation on Ali was wrong.'

b.

an t-ór seo archreid corr-dhuine go raibh se ann
this gold COMP believed a few people COMP was it there
'this gold that a few people believed (it) was there'

If the position relativized is object of preposition, the presence of a resumptive pronoun is obligatory; otherwise, the result will be ungrammatical as in (9b).

(9a)
mærd-i ke šoma diruz æz u pul gereftid ...
 man-RES COMP you yesterday from **he** money take-PAST-2pl
 ‘The man from whom you took money yesterday ...’

(9b)
 **mærd-i ke šoma diruz æz _____ pul gereftid ...*
 man-RES COMP you yesterday from _____ money took-2pl

It is worth mentioning here that ‘pied piping’ (Ross 1967) is not allowed in Persian RCs³. Examples in (10) illustrate.

(10a)
 ... *mærd-i ke be šoma pul dad ...*
 ...man-RES COMP to you money give-PAST-3sg...
 ‘...the man who gave money to you...’

(10b)
 **mærd-i be ke šoma pul dad...*
 man-RES to COMP you money give-PAST-3sg

Table 1 also shows that if the position relativized is that of the possessor, a resumptive pronoun must be present. This is contrasted in (11a) and (11b).

(11a)
mærd-i [ke pirahæn-e u zærd æst] ...
 man-RES COMP shirt-EZ **he** yellow be-PRES-3sg
 ‘The man whose shirt is yellow ...’

(11b)
 **mærd-i [ke pirahæn _____ zærd æst] ...*
 man-RES COMP shirt _____ yellow be-PRES-3sg

As for the direct object position, we saw earlier in examples (6a) and (6b) above that Persian allows both gaps and resumptive pronouns. Example (12), taken from Safavi (1994: 187), provides further evidence in this regard as both readings are grammatical.

³ This is, of course, a consequence of the fact that *ke* is a complementizer.

(12)

hušəŋg ketab-i ra [ke pesaræm (an ra) xarideh-bud] dozdid
Hushang book-RES RA COMP son-my (it RA) buy-PP-3sg stole-3sg
'Hushang stole the book that my son had bought for me.'

Above, I have noted some differences between Persian gaps and RPs. I shall now highlight some similarities. I will provide below a variety of evidence in favour of this similarity from the following phenomena: (i) coordinate structures, (ii) parasitic gaps, (iii) crossover, and (iv) island constraints.

A strong argument in support of how similar resumptive pronouns and gaps are comes from coordinate structures. The examples in (13) show that if in unbounded dependency constructions, there is a gap in one conjunct of a coordinate structure, we cannot have an NP in the other.

(13a)

The man that I think Hobbs dislikes ____ and Rhodes hates _____

(13b)

*The man that I think Hobbs dislikes ____ and Rhodes hates Trumper

Data from Persian also show that this language is sensitive to the Coordinate Structure Constraint. The pair of sentences in (14) illustrates.

(14a)

mærd-i ke šoma ____ molaqat kærdid va ____ kolah be sær dašt
man-RES COMP you ____ visist-PAST-2pl and ____ hat wore-3sg
'The man that you visited ____ and ____ was wearing a hat'

(14b)

**mærd-i ke šoma ____ molaqat kærdid va Yasmin kolah be+sær+dašt*
man-RES COMP you ____ visist-PAST-2pl and Yasmin hat wore-3sg
'The man that you visited ____ and Yasmin was wearing a hat'

Although the above examples show that a gap in one conjunct cannot co-occur with an NP in the other, the example in (15) from Sells (cited in Vaillette, 2000) illustrates how it is possible to have a gap in one conjunct and a resumptive pronoun in the other in Hebrew.

(15)

kol profesor še dani roce le hazmin _____i aval lo maarix ?oto_i maspik
every prof. that Dani wants to-invite _____i but not esteems **him**_i enough
'every professor that Dani wants to invite but doesn't respect enough'

From Swedish, Engdahl (1985:8) provides additional data in support of this argument. Example (16) shows how clauses with resumptive pronouns can be conjoined with clauses with gaps in Swedish.

(16)

Det finns vissa ord (som_i) jag ofta träffar på _____i men inte
 There are certain words that I often meet _____i but not

*minns hur **de**_i stavas.*

remember how **they** are-spelled

‘There are certain words that I often come across but never remember how they are spelled.’

Examples (17a) to (17d) show how in Persian unbounded dependency constructions a resumptive pronoun can also be used with a gap in coordinate structures. In fact, in this language, it is possible to have gaps in both conjuncts, resumptive pronouns in both, or a gap in one conjunct and a resumptive pronoun in the other.

(17a)

mærd-i ke šoma ____ molaqat+kærdid va ____ kolah be+sær+dašt
 man-RES COMP you ____ visist-PAST-2pl and ____ hat wear-PAST-3sg

æli bud.

Ali be-PAST-3sg

‘The man that you visited ____ and ____ was wearing a hat was Ali.’

(17b)

*mærd-i ke pirahænæš zærd bud væ šoma be **u** ab*
 man-RES COMP shirt-his yellow be-PAST-3sg and you to **him** water

dadid

give-PAST-2pl

æli bud.

Ali be-PAST-3sg

‘The man whose shirt was yellow and you gave him water was Ali.’

(17c)

mærd-i ke _____ pirahæn-e zærd pušideh+bud væ shoma
man-RES COMP _____ shirt-EZ yellow wear-PRESPART-3sg and you

diruz az u pul qærz+gereftid Ali bud.
yesterday from **him** money borrow-PAST-2pl Ali be-
PAST-3sg

‘The man who was wearing a yellow shirt and you borrowed money from was Ali.’

(17d)

mærd-i ke shoma az u pul qærz+gereftid væ
man-RES COMP you from **him** money borrow-PAST-2pl and

_____ *pirahæn-e zærd pušideh+bud Ali bud.*
_____ shirt-EZ yellow wear-PRESPART-3sg Ali be-PAST-3sg

‘The man who you borrowed money from and was wearing a yellow shirt was Ali.’

Another argument that supports the similarity of resumptive pronouns and gaps comes from parasitic gaps. A parasitic gap is a gap which is only possible because there is a ‘real’ gap in the same structure. English sentences (18a) and (18b) contain two gaps each. In (18a), the first gap is parasitic; while in (18b), the parasitic gap is the second.⁴

(18)

- a. Which man do you think stories about _____ really annoy _____?
- b. Which book did he criticise _____ without reading _____?

The pair of sentences in (19) shows how other NPs cannot grammatically license the parasitic gaps in (18).

(19)

- a. *Which man do you think stories about _____ really annoy Kim?
- b. *Which book did he criticise the introduction without reading _____?

However, despite Chomsky’s (1982) prediction that resumptive pronouns should not license parasitic gaps, Engdahl (1985:7) shows that this prediction seems to

⁴ This is now controversial. Levine and Sag (2003) argue that neither gap is really parasitic in an example like (18b), although the second gap is traditionally seen as parasitic.

be falsified by data like that in (20) below from Swedish. This example gives a well-formed RC containing a resumptive pronoun *han* and a parasitic gap in the adjunct clause, shown by *p*.

(20)

Det var den fången_i som läkarna inte kunde avgöra
 It was that prisoner that the-doctors not could decide

[som han_i verklingen var sjuk]
 if he really was ill

[utan att tala med p personligen].
 without to talk with ___ in person

Sells (1987: 266) also cites example (21) to show that, in Hebrew as well, resumptive pronouns can license parasitic gaps. In this example, the parasitic gap, inside the subject NP is licensed by a resumptive pronoun inside the VP.

(21)

rina hi ha'isha še [ha'anašim še ani šixnati levaker ____i] [te'aru ota_i]
 Rina is the-woman_i that the-people that I convinced to-visit ____i described
her_i 'Rina is the woman that the people that I convinced to visit ___ described.'

Persian data also provide further evidence in support of the idea that resumptive pronouns, like gaps, can license parasitic gaps. Karimi (1999:705) cites examples (22a) and (22b) to illustrate this possibility. In (22a) there are two gaps, the second of which is parasitic. (22b) shows a sentence in which the second gap is still parasitic but it is licensed by the resumptive pronoun *un*.

(22a)

Kimea in ketab ro ghablaz in ke ___ bexuneh ___ be man dad.
 Kimea this book RA before this that ___ SUB-read-3sg ___ to me gave-3sg
 'Kimea gave me this book before reading (it).'

(22b)

Kimea in ketab ro ghablaz in ke unro bexuneh ___ be man dad.
 Kimea this book RA before this that it+RA SUB-read-3sg ___ to me gave-3sg
 'Kimea gave me this book before reading (it).'

In addition to coordinate constructions and parasitic gaps, crossover effect ⁵ also provides further support for the similarity of Persian gaps and RPs. Examples in (23) show that Persian gaps are sensitive to crossover effects. Strong and weak crossover effects in Persian are illustrated in (23a) and (23b), respectively.

(23)

a. **Ki_i un_i fekr mikoneh ___ un kar ro kærð?*
 Who_i he_i think-PRES-3sg ___ that work RA did?
 ‘Who_i does he_i think did it?’

b. **Ki_i ra madæresh_i ___ dust dareh?*
 Who_i RA mother-**his_i** ___ love-PRES-3sg?
 ‘Who_i does his_i mother love?’

To see if resumptive pronouns, like gaps, exhibit crossover effects, McCloskey (1990) cites example (24) from Irish. This sentence is perfectly grammatical, apparently showing that resumptive pronouns in Irish are not subject to crossover effect.

(24)

Cé ar shíl tú gur dhúirt sé go bpósfadh Máire é?
 Who COMP_{pro} thought you COMP said **he** COMP would-marry Mary **him**
 *‘Who_j did you think that he_j said that Mary would marry t_j?’

However, McCloskey (1990), Shlonsky (1992) and Vaillette (2000) all note that in examples like (24), where we have two pronouns and no gaps, there will normally be no reason why the leftmost or the highest pronoun should not be a resumptive one. In such cases, the other pronoun will be a normal (not resumptive) pronoun, which is simply coindexed with the first one.

⁵ Of course there is no actual crossover in a non-transformational framework. Essentially what is ruled out is a coindexed constituent between the top and the bottom of an unbounded dependency.

To show that resumptive pronouns are indeed sensitive to crossover effects, McCloskey (1990), Shlonsky (1992) and Vaillette (2000) provide examples in which the first or the highest pronoun is replaced by an epithet⁶. Epithets remove the ambiguity inherent in pronouns as they are not used resumptively.

Following this technique, I provide sentence (25) which shows that Persian resumptive pronouns, like gaps in this language, are sensitive to crossover effect.

(25)

**pesær_i-i* [*ke æhmæq_i goft* *Mæryæm baš_i ærusi mikoneh*].
 boy-RES COMP idiot said-3sg Maryam with+**him** marry-PRES-3sg
 ‘The boy_i that the idiot_i said Maryam would marry him_i’

In (25), the epithet *æhmæq*, ‘idiot’ appears between the top of the dependency and the resumptive pronoun *š*, ‘him’. They are all co-indexed and the epithet, which is below the retrieval site of the dependency cannot bind the resumptive pronoun (in GB terms, the epithet c-commands the RP). Therefore, the result is ungrammatical.

Perhaps the most important support for the similarity of gaps and resumptive pronouns in Persian comes from the Island Constraints. Persian data shows that Persian resumptive pronouns, like gaps in this language, are sensitive to certain islands. Here, I will examine the Subject Condition, the Complex NP Constraint, and the Coordinate Structure Constraint.

Persian gaps are sensitive to the Subject Condition as illustrated in the pair of sentences in (26). In (26a), the subject is put in brackets and it acts like an island for unbounded dependencies as they cannot cross the boundary of the subject. For example, (26b) is ungrammatical because the question word is separated from the gap by the boundary of a subject NP.

(26a)

[*in ede’a ke Ali Hæmid ra dideh*] *Yasmin ra narahat kærd*.
 [this claim COMP Ali Hamid RA see-PP-3sg] Yasmin RA annoyed
 ‘The claim that Ali has seen Hamid annoyed Yasmin.’

(26b)

**ki* [*in ede’a ke Ali ___ dideh*] *Yasmin ra narahat kærd?*
 who [this claim that Ali ___see-PP-3sg] Yasmin RA annoyed.
 ‘Who the claim that Ali has seen ___ annoyed Yasmin?’

⁶ By epithet, it is here meant an abusive word occurring in place of the name of a person or thing or a pronoun referring to such a name or thing.

The same constraint contributes to the ungrammaticality of (27b) below as the unbounded dependency crosses the boundary of the subject.

(27a)
mærd-i ra ke Ali _____ molaqat+kærd
 man-RES RA COMP Ali Ø meet-PAST-3sg
 ‘The man that Ali met ____.’

(27b)
 **mærd-i ra ke [in ede’a ke Ali __ molaqat+kærd] Yasmin ra narahat+kærd?*
 man-RES RA COMP[this claim that Ali __ see-PP-3sg] Yasmin RA annoyed.
 ‘The man the claim that Ali has seen ____ annoyed Yasmin?’

Borer (cited in Vaillette's (2000)) shows how resumptive pronouns in Hebrew are exempt from certain islands⁷. While (28) is ungrammatical with the gap, it is grammatical with the resumptive pronoun.

(28)
*ha-yeled_i še dalya makira ?et ha-?iša še ?ohevet ?oto_i/*_____i*
 the-boy_i that Dalya knows ACC the-woman that loves **him_i**/*_____i
 ‘the boy that Dalya knows the woman who loves him’

Vaillette (2000) notes that there are languages (e.g. Igbo and Palauan) in which resumptive pronouns are also sensitive to island constraints. The following example from Persian shows that if we had a resumptive pronoun instead of the gap in (27c), the result would still be ungrammatical as shown in (29). This suggests that Persian resumptive pronouns, like gaps, are sensitive to the Subject Condition.

(29)
 mærd-i ke [in ede’a ke Ali **u ra molaqat+kærd] Yasmin ra narahat+kærd?*
 man-RES COMP[this claim that Ali **him** see-PP-3sg] Yasmin RA annoyed.
 ‘The man the claim that Ali has seen ____ annoyed Yasmin?’

This is where (30), which is equivalent of (27a) with a resumptive pronoun is grammatical.

(30)
*mærd-i ke Ali **u** ra molaqat+kærd*
 man-RES COMP Ali **him** RA meet-PAST-3sg
 ‘The man that Ali met ***him**.’

Another island constraint that applies to Persian is Complex NP Constraint. Borsley (1999:207) notes that “a *wh*-dependency cannot cross the boundary of a

⁷ It is the same in Irish, and probably in lots of languages.

clause and the NP that contains it.” Miremadi (1997: 197) cites the pair of sentences in (31) to illustrate the violation of this constraint in Persian. The complex NP is put in brackets.

(31a)

[*in ede'a ke Hassan æz Ali dær dærsæš piši*
 this claim COMP Hassan than Ali in study-his ahead

gerefteh+æst] baværkærdæni nist
 achieve-PRES PERF-3sg believable NEG-be-PRES-3sg
 ‘The claim that Hassan has achieved more than Ali in his studies is not believable.’

(31b)

**che-kæsi in ede'a ke Hassan æz ___ dær*
 who this claim that Hassan than ___ in

dærsæš piši gerefteh+æst baværkærdæni nist.
 study-his ahead achieve believable NEG-be-PRES-3sg

Again, like gaps, resumptive pronouns are sensitive to this constraint, as I have illustrated in (31c).

(31c)

**pesær-i ke in ede'a ke Hassan æz u dær*
 boy-RES COMP this claim that Hassan than **him** in

dærsæš piši gerefteh+æst baværkærdæni nist ...
 study-his ahead achieve believable NEG-be-PRES-3sg ...

The third island constraint that I will consider here is the way coordinate structures behave like islands. Borsley (1999:207) notes that “a *wh*-dependency cannot cross the boundary of a coordinate structure unless it affects every conjunct.”

Persian example (32a) is ungrammatical because, in the coordinate structure, the question word *ki*, ‘who’, has crossed the boundary of the first conjunct but not the second. So, the first conjunct works as an island. However, in (32b) the dependency crosses both conjuncts, and therefore, the result is grammatical.

(32a)

**ki bud ke šoma ___ molaqat+kærdid væ Yasmin kolah be+sær+dašt?*
 Who was COMP you ___ visist-PAST-2pl and Yasmin hat wore-3sg?

‘Who was (the man) that you visited ___ and Yasmin was wearing a hat?’

(32b)

ki bud ke šoma ___ molaqat+kærdid væ ___ kolah be+sær+dašt?

Who was COMP you ___ visist-PAST-2pl and ___ hat wore-3sg?

‘Who was (the man) that you visited ___ and ___ was wearing a hat?’

In (32b), both conjuncts contain gaps. However, in (33), we have a pair of sentences with resumptive pronouns.

(33a)

mard-i ke šoma u ra molaqat+kærdid væ be u pul dadid ...
man-RES COMP you **him** RA visited and to **him** money gave...

‘The man that you visited (***him**) and gave (***him**) money to...’

(33b)

**mard-i ke šoma u ra molaqat+kærdid va be Yasmin pul dadid...*
man-RES that you **him** RA visited and to Yasmin money gave...

The example in (33a) is grammatical and shows that the Coordinate Structure Constraint is observed. The dependency crosses both conjuncts, containing resumptive pronouns. Not surprisingly, (33b) is ungrammatical because the dependency has affected only the first conjunct, and not the second.

3 The Analysis

Relative Clause constructions in Persian are unbounded dependency constructions (UDCs). (34) shows the schematic structure of Persian RCs.

(34)

NP [*ke* ___/RP]

I assume that the bottom of the unbounded dependency in Persian RCs involves a special sign that is either a trace or a RP⁸. I propose the lexical entry in (35) for RPs and the one in (36) for traces. These two lexical entries are the same except in two respects. Firstly, the value of the PHON feature in traces is an empty list. This means that RPs, as overt elements, have phonology but traces do not. The second difference between these two lexical entries is that the value of their GAPTYPE features is different. GAPTYPE is a feature that I have introduced in order to capture the distributional properties of RPs and traces. In this way, traces and RPs have different synsem values and this allows me to subject them to different constraints. GAPTYPE is a non-local feature whose value can be either *trace* or *rp*, for traces and RPs, respectively. The reason for distinguishing traces and RPs with a NONLOCAL feature is that this is not reflected within the

⁸ See Hukari and Levine (2003) for arguments in favour of traces.

value of SLASH; and hence, it is possible for a single unbounded dependency to be associated with a trace and an RP.

(35) Lexical Entry for a resumptive pronoun

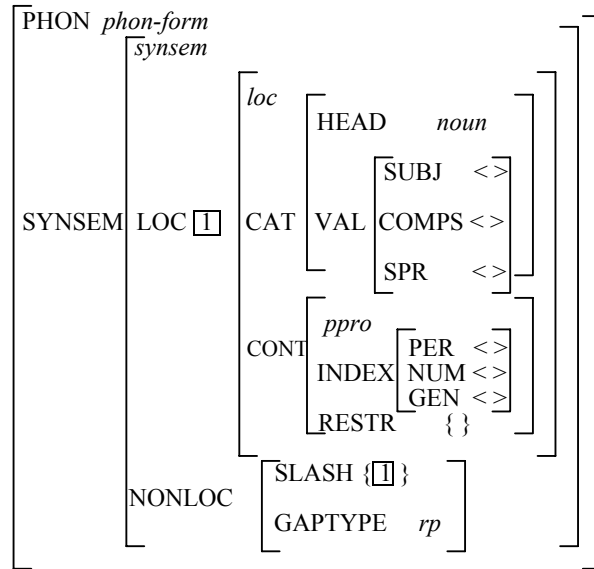

(36) Lexical Entry for a trace

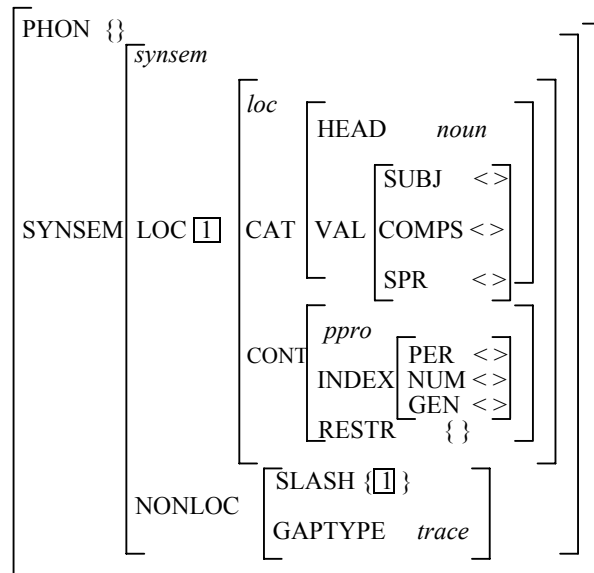

As for the pattern of distribution of RPs and traces, I will, first prevent RPs from appearing in subject position. I propose the constraint in (37) to deal with this.

$$(37) \quad [\text{SUBJ} <[1] >] \rightarrow \sim ([1] = [\text{SYNSEM}|\text{NONLOC}|\text{GAPTYPE} \text{ } rp])$$

The effect of (37) is that if an element is in subject position, then the value of its GAPTYPE feature cannot be *rp*. In other words, if an element is a RP whose value of the GAPTYPE feature is *rp*, then it cannot come in subject position.

The second constraint that I will propose here is to prevent traces from appearing in the positions of object of prepositions and possessors (i.e., in positions of the complements of non-verbs). This constraint is proposed in (38).

$$(38) \quad \left[\begin{array}{l} \text{HEAD} \quad [1] \\ \text{COMPS} < \dots, [\text{GAPTYPE } trace], \dots > \end{array} \right] \rightarrow [1] = \text{verb}$$

The effect of (38) is that if there is a trace as a complement of a head, then that head has to be a verb. Therefore, as in the case of object of preposition and genitive cases (possessors), the head is not a verb, we will not have a trace therein.

In the middle of the dependency, I do not propose anything new and will follow Sag (1997). The SLASH is inherited by two constraints: Lexical Amalgamation of SLASH, and SLASH Inheritance Principle, given in (39) and (40) below.

(39) Lexical Amalgamation of SLASH

$$word \Rightarrow \left[\begin{array}{l} \text{BIND} \quad \emptyset \\ \text{ARG-ST} < [\text{SLASH } i], \dots, [\text{SLASH } n] > \\ \text{SLASH} \quad (i + \dots + n) - \emptyset \end{array} \right]$$

(40) SLASH Inheritance Principle (SLIP):

$$hd\text{-nexus-ph} \Rightarrow \left[\begin{array}{l} \text{SLASH} / [1] \\ \text{HD-DTR} / [\text{SLASH } [1]] \end{array} \right]$$

According to (39), all words, except SLASH binding elements like *tough*, specify empty value for the feature BIND. That is, in most cases nothing is subtracted from the disjoint union of the argument's SLASH values. Therefore, if a non-head-daughter is slashed so should the head daughter.

The constraint in (40) guarantees that the SLASH value of a phrase (of the type *head-nexus-phrase*) is- by default- the SLASH value of its head-daughter. In this way, any SLASH inheritance is mediated by the head-daughter, whose SLASH value contains that of the relevant non-head daughter.⁹

One of the virtues of the present analysis is that it uses only one nonlocal feature to handle both gaps and RPs. This makes the inheritance of the nonlocal feature easy and possible in the middle of those UDCs which involve coordination of two NPs where one contains a RP and the other a gap. Other analyses (e.g., Vaillette (2000)) which utilize more than one nonlocal feature (SLASH and RESUMP) do not seem to be able to handle the inheritance of the features in such coordinate structures, contain gap in one conjunct and RP in the other.

At the top of the dependency, I will need some way to bind the SLASH feature. In other words, I will need a way to ensure that the non-empty SLASH value stops at an appropriate point. This appropriate point, in Persian RCs, is the complementizer *ke*. I will propose the lexical entry in (41) for *ke* in RCs (i.e., ke_{RC}).

The lexical entry for *ke* specifies some lexical information that ensures that the index of the N' (the NP modified by the RC) is identical to the SLASH value of *ke*. This structure-sharing, which is shown by tag [1], relates the trace or the RP to the NP modified by the RC. In addition, (12) also ensures that *ke* requires a sentential complement, shown by tag [A]. Tag [A] is the only member of *ke*'s ARG-ST list that stands for a finite sentence, containing a trace or a RP. The lexical binding of SLASH is accounted for by the feature BIND, like tough adjectives. The feature BIND has a non-empty set as value for *ke*. This is shown by tag [4]. The BIND feature will ensure that the trace or the RP is not amalgamated into the SLASH value of *ke* itself.

⁹ Ginzburg and Sag (2000) use of the Generalized Head Feature Principle to do the work of (40).

(41) Lexical Entry for ke_{RC}

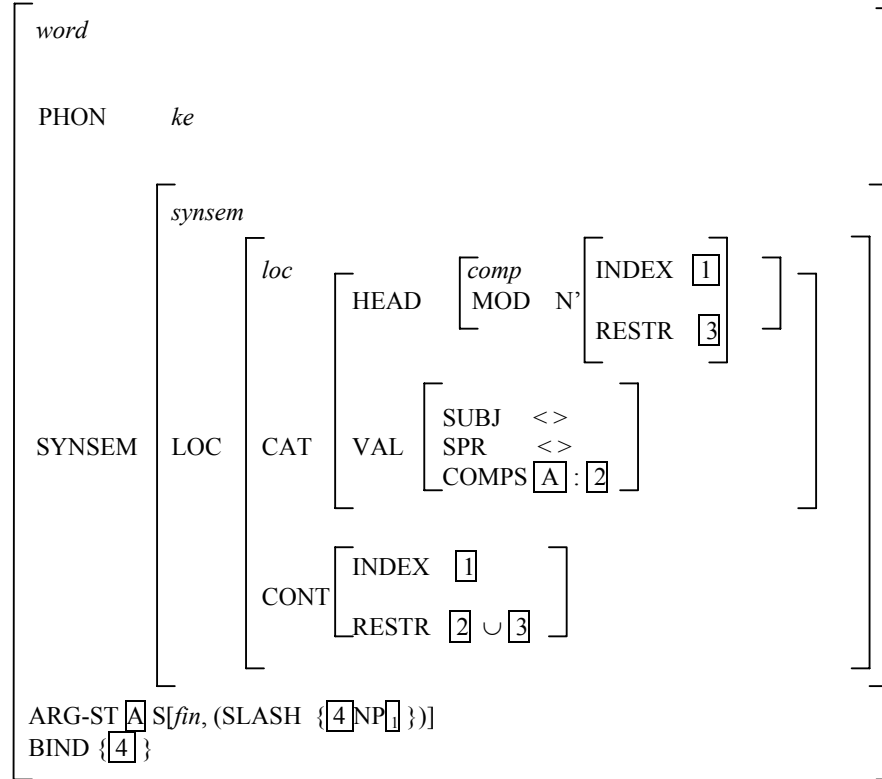

4. The Open Issues

One of the fundamental assumptions made and supported in the present paper is that there are traces in Persian RCs. An alternative analysis which someone may favour is to extend Bouma et al's (2001) traceless account to accommodate resumptive pronouns.

Also, the present analysis predicts that RPs should be okay in any unbounded dependency construction. However, they are bad in *wh*-questions. In this respect the analysis needs some refinement.

References:

- Borsley, R., 1997. *Modern Phrase Structure Grammar*. Blackwell Publishers, UK.
- Bouma, G., R. Malouf, and I. Sag, 2001. Satisfying Constraints on Extraction and Adjunction. *Natural Language and Linguistic Theory* 19:1-65.
- Chomsky, N., 1982. Some Concepts and Consequences of the Theory of Government and Binding. *Linguistic Inquiry Monograph* 6. Cambridge, Massachusetts: MIT Press.

- Dabirmoghaddam, M., 1990. On Postposition Ra in Persian. *Iranian Journal of Linguistics*. 7: 1: 2-60.
- Engdahl, E., 1985. Parasitic Gaps, Resumptive Pronouns, and Subject Extractions. *Linguistics* 23: 3-44.
- Ginzburg J. and I. Sag, 2000. *Interrogative Investigations: The Form, Meaning, and Use of English Interrogatives*. CSLI Publications, Stanford.
- Karimi, S., 1990. "Obliqueness, Specificity, and Discourse Functions: *râ* in Persian," *Linguistic Analysis*, Vol. 3&4. PP 139-191
- Karimi, S., 1999. A Note on Parasitic Gaps and Specificity. *Linguistic Inquiry* 30: 704-713.
- Levine, R. and T. Hukari, 2003. *The Unity of Unbounded Dependency Constructions*. CSLI. Stanford. California. USA.
- Levine and Sag (2003), *Some Empirical Issues in the Grammar of Extraction*, Proceedings of the HPSG03 Conference, CSLI Publications.
- McCloskey, J. 1990. Resumptive Pronouns, \bar{A} -Binding, and Levels of Representation in Irish. *Syntax and Semantics* 23: 199-248.
- Miremadi, A. 1997. *Persian Syntax: A GB-based Analysis*. SAMT Publishers, Tehran.
- Pollard C., and I. Sag, 1994. *Head-Driven Phrase Structure Grammar*. The University of Chicago Press, USA.
- Ross, J., 1967. *Constraints on Variables in Syntax*. Doctoral Dissertation. MIT, Cambridge, Massachusetts.
- Safavi, K., 1994. *Some Properties of Persian Relative Clauses*. Proceedings of the 2nd Conference on Persian Linguistics, Allameh Tabatabaie University, Tehran.
- Sag, I., 1997. English Relative Clause Constructions. *Journal of Linguistics* 33: 431-484.
- Sells, P., 1987. Binding Resumptive Pronouns. *Linguistics and Philosophy* 10: 261-298.
- Vaillette, N., 2001. *Hebrew Relative Clauses in HPSG*. Proceedings of the 7th International Conference on Head-Driven Phrase Structure Grammar, CSLI Publications.