

Uncovering regularities:
On Bare and Evaluated Controllers in Tigrinya

Jonathan Allen Brindle

Norges Teknisk-Naturvitenskapelige Universitet

Proceedings of the HPSG06 Conference

Linguistic Modelling Laboratory
Institute for Parallel Processing
Bulgarian Academy of Sciences
Sofia
Held in Varna

Stefan Müller (Editor)

2006

CSLI Publications

<http://csli-publications.stanford.edu/>

1 Introduction

This paper presents an investigation of the gender system in Tigrinya (ISO/DIS 639- 3:tir)¹. Considering the literature on the topic (see under *gender* or *genre* in Schreiber (1887); Leslau (1941); Agostinos (1994); Lipiński (2001)) in which it is basically presented as a “flexible” or “free” gender system, the present analysis predicts the behavior of gender in the language. The following exemplifies what we believe is the issue to cover.

- (1) a. $mat'haf$ “a book”
- b. $qayyih_{masc} mat'haf$ “a red book”
- c. $qayyah_{fem} mat'haf$ “a red (beloved, small or particular) book”

Following Corbett (Corbett, 1991; Corbett and Fraser, 2000; Corbett, 2001, 2006), we assume that a nominal classification (i.e. genders or noun classes) in a language reduces to the evidences the agreement system of the language provides. Tigrinya has two values for gender traditionally labeled as masculine and feminine, as displayed in (1). One problem is the fact that the word for $mat'haf$; ‘book’ triggers both feminine and masculine in the same agreement domain (see Corbett, 2006, pg 4). Even more problematic is the fact that most nouns behave in the same way. While one can say that speakers of Tigrinya have the liberty of choice, such an assumption creates several problems, among others: (i) the existence of a language having an *unsystematic* gender *system*² and (ii) reduplication in the lexicon, for each noun must trigger the right value for gender³.

2 Typology

It is important to make a division between a primary and a secondary role or function of gender values, irrespective of them being natural or grammatical. On the one hand the inherent values for gender are those associated with nominals at the lexical level, be it semantically or formally assigned by the speaker. On the other hand a noun can trigger a different value than its inherent one on target(s). In that case it appears that the noun has undergone a *gender shift*. To present the sort of phenomenon we are concerned with, let’s consider the following data from Swahili and Kasem. In Swahili (Table 1) building an augmentative out of a given noun is done by gender shift. The word for *basket* is in class (cl.) 9/10 in unmarked cases but shifts to cl. 5/6 and/or cl. 3/4. For Kasem (Table 2), cl. 1 in the first column is

¹<http://www.ethnologue.com/showlanguage.asp?code=tir>

²Considering Corbett’s explanation of *double* or *multi-gender nouns* as non applicable (Corbett, 1991, pg 181).

³As we endorse Corbett’s typology of agreement (Corbett, 2006), underspecifying each noun for its gender value cannot be done for directionality reasons; a noun acts as a controller and determines a particular feature’s value on a target. However, it is still possible to talk about controllers even if directionality is “hidden” by unification.

is in cl. 9/10, in Kasem kaanr; ‘*woman*’ is in cl. 1 and in Tigrinya waddi; ‘*boy*’ is masculine. Since a shift is a change one needs an origin for the shift. Claiming such assignment of gender value, that is, inherent value, has a consequence in considering underspecification in the model.

The literature on evaluative morphology usually uses *quantitative* and *qualitative* as scales to which a referent is graded and compared to its standard reference. The terminology is further broken down into diminutive-augmentative and caritative-pejorative, respectively, terms which usually stand for the meaning conveyed. But nothing has ever been said about familiarity, specificity or what in section 4.3 is called particularization. Are they evaluations?

The general statements on evaluations available in the literature are : (i) they do not change the lexical meaning of the morphological base or referent, (ii) they do not change the syntactic category of the lexeme, (iii) they reflect subjective attitude of the speaker and (iv) they can be recursive (Beard, 1995, pg 163). The signals can take different forms: many languages use affixes (Grandi and Montermini, 2003), others use a gender shift.

It can be said that for a language X to have gender shift, X must have a semantically-based nominal classification. The secondary function of gender comes in if at first place gender could convey sense outside its primary assignment. Notice that only nominals are analysed in the present work, but evidences from many languages tell us that pronouns and adjectives (i.e. at least those used predicatively) are also susceptible to undergo evaluation (see Geertz, 1960; Slobin, 1963; Brown and Gilman, 1960; Das, 1968).

3 Nominal Classification

It is shown in Corbett (1991, pg 7) that assigning a class to a noun depends on semantic or phonological criteria, or a mixture of both. As argued in Brindle (2005a, pg 36) Tigrinya speakers assign classes to nouns following semantic criteria (see also Leslau, 1941).

(3) *Semantic criteria*

- Sex-differentiable entities denoting females are feminine (e.g. living organisms).
- Sex-differentiable entities denoting males are masculine (e.g. living organisms).
- Animals are assigned either feminine or masculine, somehow reflecting aggressiveness, size and wiseness dimension.
- Some small items are assigned feminine gender (i.e. lexicalized diminutives)
- Some items with power and respect connotation are masculine.

- Some items with wiseness or fertility connotation are feminine.
- Country names are assigned feminine gender
- Collective of inhabitants are assigned masculine gender
- The moon and the sun are feminine
- A corpse, irrespective of the dead's sex, is masculine

The first two criteria are seen in gender systems cross-linguistically. The third one applies when animals are referred to without reference to their sex. Notice that at the bottom of the list, the criteria are much less generalizing. However, these are generalisations that seem to hold according to native speakers and in canonical agreement. The criteria allow the separation of the nouns in a hierarchy as in Figure 1. Going down the hierarchy, two mutually exclusive classes are created: *Class-I* and *Class-II*.

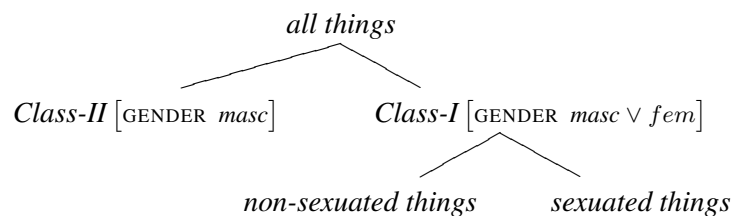

Figure 1: Classification Hierarchy

The dichotomy is defined as follows: nouns are of *Class-I* if they satisfy at least one criterion in the list of semantic criteria. Under *Class-I*, a distinction is made between *sexuated things* and *non-sexuated things*. Under *sexuated things*, grammatical gender assignments follow from natural gender. They are automatically assigned masculine or feminine, respecting a male/female distinction. A more complex issue is the classification of the non-sexuated things. Animals are good examples to motivate some of the criteria in the list. They are classified according to how they are seen by the linguistic community following concepts like strength, aggression, fertility, stupidity and so on.

All *Class-II* nouns are masculine. Contrary to *Class-I* nouns, the masculine value is seen as a default; *Class-II* are residuals. Understandably, one might wonder what the evidence is for a split between *non-sexuated Class-I masculine* and *Class-II* nouns, since they both trigger masculine on target(s): the answer is that *Class-II* gathers nouns that are **not** satisfying one of the semantic criteria. The distinction between *Class-I* and *Class-II* gets further motivated when one observes which evaluation is appropriate for each class. We will show that *Class-II* nouns are appropriate candidates for certain types of evaluations, while *Class-I* are appropriate for others. We believe that this situation brings an argument in favor of the classification proposed. Therefore, apart from a classification separating nouns into two genders based on the agreement system operating in the language (i.e.

masculine and feminine), we propose two classes of nouns in Tigrinya (i.e. *Class-I* and *Class-II*) derived from semantic criteria.

4 Evaluations

What is an evaluation in Tigrinya?

4.1 qualitative-/quantitative+

It is easy to insult a man: simply mark the target(s) in a construction with feminine.⁴ Using feminine value for gender for a male is read as an insult. These usages are categorized as diminishing the status of a male. In example (4) we see the effect on gender when reference is made to an animal.

- (4) a. zibʔi bi-t'ik'ay halifom , bi-firhat riʕida
 hyena by-near passed.MASC , in-fear shook.1.MASC.SG
 'A group of hyena passed near me, I was terrified' (Brindle, 2005b)
- b. zibʔi bi-t'ik'ay halifan , gina hanti ʔaygabaganin
 hyena by-near passed.FEM , but nothing/one did.not.3.PL
 'A group of hyena passed near me, they did not hurt me' (Brindle, 2005b)

The word zibʔi; 'hyena' is in *Class-I masculine*, value assigned by the semantic criteria. In (4a) the word triggers masculine on the verb, but in (4b) it triggers feminine. In both of these sentences, the word zibʔi manages to determine either feminine or masculine on the target verb. This is an evidence which shows a change

⁴Evaluations of that sort are even penalised by customary laws. The following examples are taken from the written customary laws of the highlands of Eritrea.

- (1) ni-tabafitay ʔatti innabala ba-nistayti zi-t'arafala 12 hilqi
 to-male pro.2.FEM.SG saying in-female who-insults 12 hilqi
 yaxhas
 he.should.pay.indemnity
 'If a person insults a male (man) in a female form (grammatical expression), then as indemnity, he should pay 12 helqi' (Law (1918))
- (2) bi-g'al ʔanstayti zi-t'awfe ... 110 qirfi yaxhas ...
 to-girl female who-calls ... 110 qirsi he.must.pay.as.indemnity ...
 'Who calls a man by a female form, must pay 110 qirsi as indemnity' (Law (1946))

in its agreement class. This is understood as the aggressiveness status of a typical hyena is being diminished.⁵ Now look at the following examples:

- (5) ?izza waddi bA-ʕalti siɾɿA ?imbar
 DEMART.FEM.SG boy of-owner.FEM.SG pants indeed
 koyɿ-a
 become; \sqrt{kwm} :||A.PERF.FEM.SG||
 ‘This boy became courageous’ (Gebrechristos, 1993, pg. 97)

- (6) ?izza waddi maʕant'a ?imbar gAjjira
 DEMART.FEM.SG boy intestine indeed do; \sqrt{gbr} :||A.PERF.FEM.SG||
 ‘This boy became courageous’ (Gebrechristos, 1993, pg. 139)

Sentences (5) and (6) are appropriate in a context in which a timid young boy suddenly becomes energetic, outspoken or even aggressive. At a certain moment, contrary to all expectations, he behaves in opposition to his socially substract nature. In fact, the verb phrases in these examples are considered idioms, but we still consider them evidence for satiric connotation since the inherent gender of the word for “boy” has shifted (i.e. target ?izza.FEM, not ?izzu.MASC). We showed that using feminine value for gender to a male is not only read as insulting but could also in some context be regarded as satiric. This occurs specifically to males. Now consider the opposite situation for an adult female.

- (7) ?izzi sabAjtɿ jinAbih ?allo
 DEMART.MASC.SG woman bark AUX.MASC.SG
 ‘This woman is shouting (at somebody)’ (Brindle, 2005b)

The same evaluation can apply on sabAjtɿ; ‘woman’ in (7) but there the gender shift goes *fem* → *masc* instead of the *masc* → *fem*. The semantic effect of gender shift emphasizes the aggressiveness or insensibleness of that particular woman.

⁵The nominal in (4) is used for collective reference. Further, consider this verse of a traditional children song.

- (1) zib?i tiwalid ?alla, ?izgi ?ajaʕibjalla
 hyena giving.birth is.FEM, God not.grow.up.FEM
 ‘A hyena is giving birth, God don’t let them grow up!’ (Brindle, 2005b)

In that verse the word zib?i; ‘hyena’ must refer to female since only female hyena can give birth, so the use of feminine is covered by the semantic criteria, since individuated hyenas are ‘sexually’ classified. Thus example (1) is not a case of evaluation.

4.2 qualitative+/-quantitative-

Interestingly, diminutives with a unique meaning *small(x)* are not common, if they exist at all. These are called true diminutives in Hasselrot (1957). It was found that speakers prefer to form true diminutives synthetically (i.e. *adj* ∨ *verb* + *noun*).⁶ However, we believe that all diminutives in Tigrinya are colored by endearment. Therefore, we gather under caritative the evaluation of the type *dear(x)*, *small(x)*. This means that a translation (i.e. from native speakers) involving predicates such as *small*, *dear*, *lovely*, *close*, *affectionate*, *beloved* will treat those properties as caritative-diminutive. Friendship is another issue that we wish to include. Friendship can be thought of as an evaluation affecting only human entities or humanized characters. This evaluation seems to follow what we have gathered under caritative. Tigrinya speakers typically use these types of evaluation among close friends and (appreciated) family members. For example, Solomon is a proper name associated with a human male. In (8) speaker A and B are discussing Solomon's well-being and he is not part of the conversation.

- (8) a. A: solomon kAMAY ti-sARRih ʔall-a
 Solomon how IPFV-work.FEM.SG have-FEM.SG
 ‘How is Solomon doing?’
- b. B: nissa t'ibuq ti-sARRih ʔall-a
 3.FEM.SG fine/good IPFV-work.FEM.SG have-FEM.SG
 ‘He is doing good! (lit; She is doing good)’

Both speakers are close friends with Solomon since they both talked about him using the feminine value for gender. In this case it is a male that asks a fellow male about his present life satisfaction. While these examples involve friendship relation, the following is concerned with what we called affectionate use. Compare (9), (10) and (11):

- (9) ʔizza wAdd-AY kitzareb ɕAMmira
 DEMART.FEM.SG boy.SG-POSS.1.SG.MASC speak start
 ‘My (dear , lovely,..) son started to speak’
- (10) wAdd-AY nifuʕi ʔiyyu
 boy.SG-POSS.1.SG.MASC nice.3.MASC.SG AUXP.3.MASC.SG
 ‘My son is nice’
- (11) wAdd-AY nifiʕi-ti ʔiyya
 boy.SG-POSS.1.SG nice.3.SG-FEM AUXP.3.FEM.SG
 ‘My (dear , lovely,..) son is nice’

⁶The closest to true diminutives we have found are the lexicalized forms (i.e. some *Class-I:FEM* ending in *-t* or *-ti*) or borrowed Italian words carrying a diminutive morpheme. Italian *-ino* and *-ina* are not used outside borrowed words (mostly proper nouns) and *Class I:FEM* nouns ending in *-t* or *-ti* are considered non-decomposable.

Examples (8) to (11) all involve *Class-I* nouns, but it is easy to find *Class-II* in the case of affectionate. Having affection or appreciation toward an object can be done likewise:

(12) saʔinɒy t'ibuq ʔiyyu
 shoe.SG-POSS.1.SG nice.MASC.SG AUXP.3.MASC.SG
 'My shoe is nice'

(13) saʔinɒy t'ibuq-ti ʔiyya
 shoe.SG-POSS.1.SG nice-FEM.SG AUXP.3.FEM.SG
 'My (dear, lovely) shoe is nice'

Thus *small*, *dear*, *lovely* and *affectionate* can apply to non-human as well. The data tells us that a word of *Class-II* like saʔinɒy; 'shoe' undergoes similar process as *Class-I* nouns do when it comes to affection towards a referent. Besides, we consider the possibility for a female to undergo gender shift under that evaluation. No data are given in this work since only one speaker agreed with what we presented to her. The context in which one could retrieve gender shift on females under caritative evaluation involves the affection of a mother towards her daughter.

4.3 Particularization

We analysed all *class-II* nouns as masculine. The reason why we choose that value for gender is that, on the one hand, when a *class-II* noun determines feminine agreement, we observed a meaning difference, either a caritative or a particularization. On the other hand, when it is masculine the noun's denotation is the only representation available. We observed that Tigrinya uses gender shift on *Class-II* nouns to *particularize* or *specify* them in certain contexts. Thus we say that a noun is *particularized* by an evaluation ignoring *definiteness*. This allows a noun to not get particularized but still to receive the referential function of items bearing definiteness. Consider a *Class-II* noun and the example (14) below:

(14) ʔizzi kɒfli
 DEMART.MASC.SG room
 'this room'

Thus the noun phrase in (14) is made up of a *Class-II* noun, is definite but not particularized. Particularization is a term that is closely related to specificity and familiarity⁷. It is an evaluation found especially in indefinite singular noun phrase, but in theory since it is the controller that is evaluated, other syntactic environments are possible. In fact we shall present the consequence of this type of evaluation in a quantifier phrase in (17) below. In indefinite singular noun phrase

⁷The discussion surrounding initial vowel, also called augment, in the Bantu literature has a strong similarity with what we call particularization for Tigrinya (see de Blois, 1970; Hyman and Katamba, 1993; Petzell, 2003).

particularization is an evaluation which narrows down the identification of, renders distinct or individuates an object for both the speaker and the hearer. Both speaker and hearer should have the same object in mind. If an object gets particularized by the speaker, the hearer must have the object token in mind, not only its type⁸. This is exemplified in (15a) and (15b).

- (15) a. litfi ?all-o-ka-do
bulb have-3.MASC.SG-2.MASC.SG-QM
'Do you have a (any) bulb?'
- b. litfi ?all-ati-ka-do
bulb have-3.FEM.SG-2.MASC.SG-QM
'Do you have a (particular) bulb?'

In (15a) the customer asks the shop-keeper if he has light bulbs in his shop. The shop keeper has the bulbs in the backroom of his shop. As the customer cannot see any bulbs around on the shelves or he doesn't have a sample with him, he cannot point at them. But the context in which (15b) is uttered is that the customer has a bulb in his hand, showing the kind of bulb he is seeking to purchase but still uses an indefinite noun phrase. Notice that the meaning conveyed is better translated as a quantifier (i.e. eng: any) in (15a) and as an adjective or determiner (i.e. eng: particular, this, such) in (15b). This reflects (i.e. what we judged) the interpretations of native speakers. While in English the noun phrase in (15b) should have been used with another element in the noun phrase, Tigrinya has a grammatical device that signals the particularization of *Class-II* nouns. This device is gender shift.

- (16) a. m Δ brahti walli $\text{\textcircled{f}}$ -i-ya
electric light put.on-2.FEM.SG-3.FEM.SG
'(You_{fem}) switch on the light!'
- b. m Δ brahti walli $\text{\textcircled{f}}$ -i-yo
electric light put.on-2.FEM.SG-3.MASC.SG
'(You_{fem}) switch on a light!'

The situation is similar in (16). When m Δ brahti; '*electric light*' is used in masculine, the hearer's answer is to switch on any light in the room (i.e. the light is not specified. It could be a lamp or any other sources of electric light). If the feminine is used, the source of the light and possibly the location of the switch is known by both speaker and hearer. We decided to gloss this sentence making an *a/the* distinction in English. Further, particularization can affect the interpretation of noun phrases involving a quantifier like kwullum; '*all*'.

⁸In Borthen (2003), a *type* discourse referent is seen as a genre, a kind or a category, while a *token* discourse referent is seen as an individual or an instance of an object. A future work is to make the link between an implementation of referential properties of nominals in a HPSG grammar (Borthen and Haugereid, 2004) and the phenomenon we label *particularization*.

- (17) a. k^wullom (?itom) maʔhaf-ti
all.MASC (the.MASC) books-PL
‘all (the) books’
b. k^wullan (?itan) maʔhaf-ti
all.FEM (the.FEM) book-PL
‘all (the) books’

The meaning conveyed by the cohabitation of the particularization evaluation and a quantifier like k^wullan in (17b) is the one in which the books are seen as individuated and forming a totality (i.e. similar to the combination of ‘each’ and ‘all’ in English, some sort of distributive reading). The sentence (17a) is seen as the gathering, the whole, the totality of the books. In figure 2 we present two environments in which *particularization* have been elicited and the consequence of gender shift in the interpretation of the noun phrase.

	MASC	⇒	FEM
$[N]_{np}$	type of object	⇒	token of object
$[\forall N]_{np}$	all-whole	⇒	each-whole

Figure 2: Evaluation: particularization

Table 3 summarizes what we have presented under the term evaluations. Currently, the evaluations we are providing will obviously raise ambiguities. If one looks at the summary table, one can see overlapping statements having different evaluations. Evaluations need situation or context to be processed. Even cases in which a man insults his best friend or shows great affection towards his enemy are easily interpreted by native speakers. The pragmatic level of evaluations is left out of the present analysis.

if <i>Class-I</i> human female is assigned masculine =	status -
if <i>Class-I</i> human male is assigned feminine =	status -
if <i>Class-I</i> :MASC is assigned feminine =	status -
if <i>Class-II</i> is assigned feminine =	status+/size-
if <i>Class-I</i> human male is assigned feminine =	status +
if <i>Class-I</i> human female is assigned masculine =	status +
if <i>Class-II</i> is assigned feminine =	particularized

Table 3: Evaluations

Evaluations involve three distinguishable but inter-related parts: a lexical, a syntactic and a semantic component. In the lexical component, inherent values for gender are changed. The language having two values for gender, the given *shift* of value has only one option, the other value. The syntactic component should reflect

canonical agreement, since no agreement mismatches are observable in what we are covering (Corbett, 2006, pg 143). The controller, evaluated or not, informs the target(s) in what respect they should inflect. The semantic component of the noun stays unchanged: a male stays a male and a shoe stays a shoe. It is their agreement features, more precisely gender, that gets affected and, as we argue, this is a syntactic matter. What is happening in the semantic components is a property addition through evaluation, corresponding to what we have presented in this section. We are simply saying that a first-order logic representation of sentence (13) should look like $Dear(x) \wedge Shoe(x) \wedge Nice(x)$, and for French examples involving true diminutives *bâtonnet*: $Small(x) \wedge Stick(x)$, *garçonnet*: $Small(x) \wedge Boy(x)$, *livret*: $Small(x) \wedge Book(x)$, and so on. For all evaluations, one predicate is added to the logical formula.

5 HPSG

How do these grammatical properties look like in an HPSG architecture? The nominal classification presented in section 3 is reflected in the hierarchy under *gend*, as in Figure 3. The type *gend* is compatible with both *fem* and *masc*. The types *Class-I* and *Class-II* are abstract types reflecting the dichotomy argued for in section 3. Within the dichotomy, a noun gets assigned a value for gender. The three leaf types we get, *CI-masc*, *CI-fem* and *CII-masc* reflect the only defined types declared for gender assignment in the language.

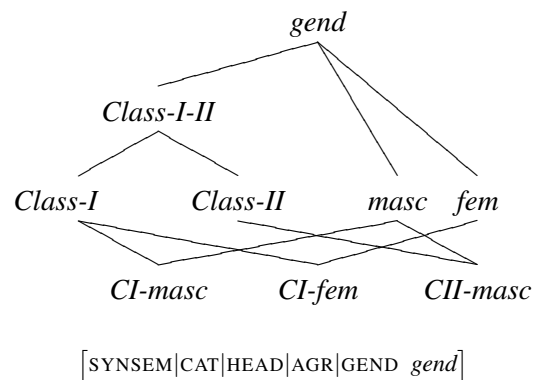

Figure 3: Gender Hierarchy

In the lexicon all nouns should have one of these types as a value for gender. That point is illustrated by taking three nouns out of the classification proposed. The differences between (18) a, b and c lie in their value for PHON, their value for PRED and their value for GEND.

- (18) a. 'shoe'

- $$\begin{array}{l}
 \left[\begin{array}{l}
 cn-lxm \\
 PHON \quad sa?ini \\
 SYNSEM \quad \left[\begin{array}{l}
 CAT|HEAD|AGR|GEND \quad CII-masc \\
 CONT|RELS|PRED \quad sa?ini
 \end{array} \right]
 \end{array} \right] \\
 \text{b. 'man'} \\
 \left[\begin{array}{l}
 cn-lxm \\
 PHON \quad sAbay \\
 SYNSEM \quad \left[\begin{array}{l}
 CAT|HEAD|AGR|GEND \quad CI-masc \\
 CONT|RELS|PRED \quad sAbay
 \end{array} \right]
 \end{array} \right] \\
 \text{c. 'woman'} \\
 \left[\begin{array}{l}
 cn-lxm \\
 PHON \quad sAbayti \\
 SYNSEM \quad \left[\begin{array}{l}
 CAT|HEAD|AGR|GEND \quad CI-fem \\
 CONT|RELS|PRED \quad sAbayti
 \end{array} \right]
 \end{array} \right]
 \end{array}$$

This organisation would allow, for example, a noun of gender *CI-fem* unifying with an adjective of gender *fem* resulting in a phrase where *fem* is the common type shared by both. For example, consider the case in which an attributive adjective and a noun combine. Following Eynde Eynde (2002), the combination of the adjective and the noun is done by a grammar rule labeled *head-functor* phrase, as described in Figure 4. The SELECT value in the functor daughter is structure-shared with the SYNSEM value in the head daughter. Moreover, adjectives have constraints specified on them which ensure that the morpho-syntactic agreement features (i.e. AGR in Kathol (1999) and Sag et al. (2003) and NUMGEN in Eynde (2002)) on the selected nominal are structure-shared with the adjective.

In section 4 evaluative morphologies were presented as operations in which (i) the resulting categories stay unchanged, (ii) they provide a flag to signal that a semantic composition is being conveyed and (iii) they add some meaning. Another property is that the “derivation” brings a lexeme into another lexeme form, evidences come from pluralisation (Derzhanski, 2003). HPSG offers an appropriate mechanism that can capture all these grammatical processes. The formalism allows us to change the value for the gender feature and to add an elementary predication through lexical rules. Even though the phenomena could be accounted for by assuming a different lexical representation for gender encoding (i.e. underspecification), respecting the typology of agreement (Corbett, 2006) and the nature of a shift place us in a situation in which evaluations can be appropriately described using lexical rules. The sort of lexical rules created to capture evaluations are derivational.⁹

⁹We did not implement the present work, but we were influenced by the Grammar Matrix (Bender et al., 2003). The *cat-E* type was conceived to be a subtype of constant lexeme-to-lexeme rule (i.e. *const-ltol-rule*), a spelling preserving rule, since the phenomena under Category E do not add overt morphological material (i.e. in Tigrinya). The term Category E is borrowed from Delhay (1996): “La *Catégorie D* est une construction abstraite destinée à rendre compte des phénomènes de construction d’un sens dit “diminutif” en contexte et ne vise pas à créer une archi-catégorie morpho-syntactique. Elle ne saurait donc se prévaloir d’une quelconque prétention à la prédictabilité, mais cherche à décrire la diversité de procédés et de valeurs que l’on peut subsumer sous l’idée de DIMINUTION.” Thus Category E is seen here as a global term scoping over a family of evaluations on nouns,

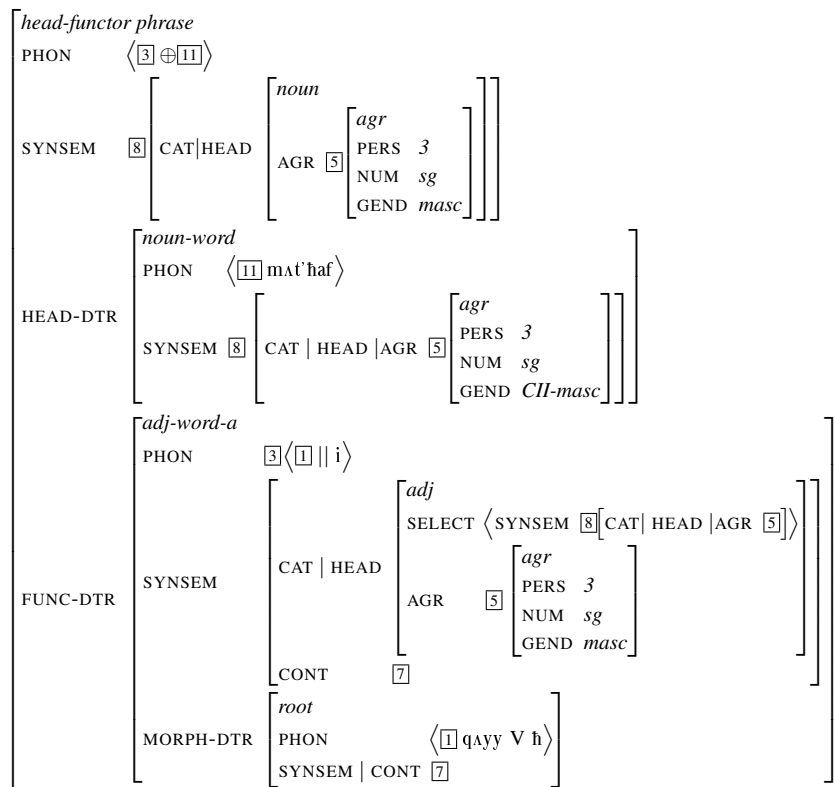

Figure 4: Composition of qayyih mat'haf 'a red_{masc} book'

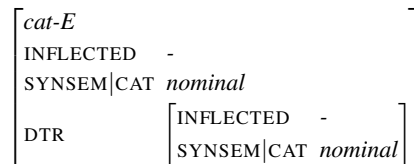

Figure 5: *cat-E* type ("subtype" of *const-1tol-rule* (Bender et al., 2003))

The type *cat-E* displayed in figure 5 is the root of the family of evaluations. It inherits the constraints declared on the type *lexeme-to-lexeme-rule*, that is, the constraints that interest us are in a rule in which (i) the input and the output are not fully inflected and (ii) the rule has one daughter, the input. The input for *cat-E* is always a nominal and under this rule, nominals cannot undergo a categorial change. The semantic representation in figure 6 is a simplified form of Minimal Recursion Semantics (MRS).¹⁰ The *mrs* type declares two features: INDEX and RELS. The feature INDEX can take two values, *event* or *ref-ind*. The value of INDEX is unified

grammatically signalled by gender shift. Contrary to her Category D, Tigrinya offers other types of evaluation and lacks some of the compositions French offers.

¹⁰Simplified form in the sense that we use only some features declared on a full fledged MRS (Copestake et al., 2006) to accommodate the phenomena in question.

with the value of ARG0 in RELS. Figure 7 displays the TFS of a type labeled *sem-cat-E*, a type which constrains the insertion of a particular relation in the bag, an *arg1-rel*.

$$\left[\begin{array}{l} mrs \\ \text{INDEX } \boxed{5} \\ \text{RELS } \left\langle ! \left[\begin{array}{l} \textit{noun-rel} \\ \text{PRED } \textit{string} \\ \text{ARG0 } \boxed{5} \end{array} \right] ! \right\rangle \end{array} \right]$$

Figure 6: Reduced *mrs* type

$$\left[\begin{array}{l} \textit{sem-cat-E} \\ \text{INFLECTED -} \\ \text{SYNSEM} \\ \text{DTR} \end{array} \right] \left[\begin{array}{l} \text{CAT } \textit{nominal} \\ \text{CONT|RELS } \left\langle ! \boxed{2} \left[\begin{array}{l} \textit{noun-rel} \\ \text{ARG0 } \boxed{3} \end{array} \right] , \left[\begin{array}{l} \textit{arg1-rel} \\ \text{PRED } \textit{string} \\ \text{ARG0 } y \\ \text{ARG1 } \boxed{3} \end{array} \right] ! \right\rangle \\ \text{INFLECTED -} \\ \text{SYNSEM } \left[\begin{array}{l} \text{CAT } \textit{nominal} \\ \text{CONT|RELS } \langle ! \boxed{2} ! \rangle \end{array} \right] \end{array} \right]$$

Figure 7: *sem-cat-E* type

In Figure 7, the type *sem-cat-E* constrains the output of the rule to contain an additional elementary predication (EP) in the RELS's list. This elementary predication (i.e. *arg1-rel*) is the locus of evaluation. It corresponds to the meaning representation of *-ette* in French, *-ish* in East Cree (Junker et al., 2002) and likewise in other languages having evaluative morphology.

$$\left[\begin{array}{l} \textit{arg1-rel} \\ \text{PRED } \textit{string} \\ \text{ARG0 } \textit{event} \\ \text{ARG1 } \textit{ref-ind} \end{array} \right]$$

Figure 8: *arg1-rel* Relation

The hierarchy in Figure 9 shows three subtypes of *sem-cat-E*: *quant-/qual+*, *particu* and *quant+/qual-*. Each type constrains the appropriate nominal it can add an evaluation to, using the *gend* type introduced earlier¹¹. These act as filters, blocking some undesirable evaluations. For example, such declaration restricts the *particu* evaluation to be compatible only with GEND *Class-II*, *quant-/qual+* with *Class-I-II* (i.e. underspecified) and *quant+/qual-* with *Class-I*.

¹¹In Figure 9 the feature GEND ends the following path in the three lowest type: [DTR|SYNSEM|CAT|HEAD|AGR|GEND *Class-I-II* ∨ *Class-I* ∨ *Class-II*]

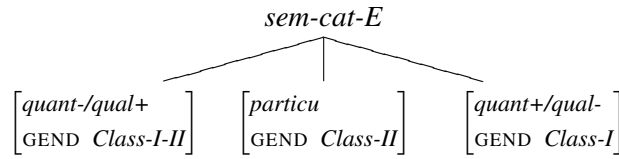
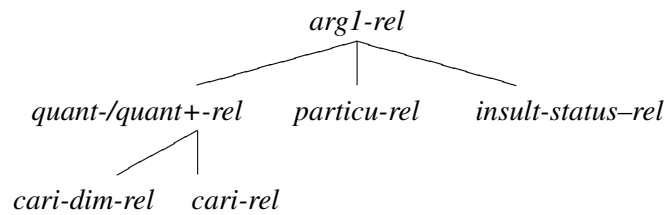

Figure 9: sem-cat-E subtypes

The type *arg1-rel* has subtypes, corresponding to the findings shown in section 4. The hierarchy in Figure 10 displays evaluation relation possibilities. Moreover, *arg1-rel* types constrain the relation with a value for PRED.



<i>cari-dim-rel</i>	PRED “ <i>small-beloved</i> ”
<i>cari-rel</i>	PRED “ <i>beloved</i> ”
<i>particu-rel</i>	PRED “ <i>particular</i> ”
<i>insult-status-rel</i>	PRED “ <i>status -</i> ”

Figure 10: Hierarchy of Evaluation Relations and respective PRED Value

The notion of friendship and insult is seen as only applicable to humans. The semantic representation of INDEX is extended, using the SORT feature, to split things in the world that are human or not with the feature HUMAN having *bool* as a value, where *bool* represents +/-.

- (19) *Human or not in a Sign*
 [SYNSEM|CONT|INDEX|SORT|HUMAN *bool*]

With that in mind, there are two rules which can apply to nouns that are constrained as HUMAN +. These rules are appropriately used in cases where humans are endeared or insulted. Augmented with that constraint, lexical rules built from the types *insult* and *cari* are appropriate only for nouns having that feature. Figure 11 illustrates the constraints gathered under the *insult* type.

- (20) a. $\left[\begin{array}{l} ge-sh-fem \\ \text{SYNSEM|CAT|HEAD|AGR|GEND} \quad fem \\ \text{DTR|SYNSEM|CAT|HEAD|AGR|GEND} \quad masc \end{array} \right]$
 b. $\left[\begin{array}{l} ge-sh-masc \\ \text{SYNSEM|CAT|HEAD|AGR|GEND} \quad masc \\ \text{DTR|SYNSEM|CAT|HEAD|AGR|GEND} \quad fem \end{array} \right]$

j. ? *ge-sh-masc* \sqcap *status-*

Figure 13 provides one of them. This rule is typed *ge-sh-fem-cari-dim-rule*. The rule is constrained, so either *Class-I* or *Class-II* is a possible input and gender shift needs anything that has masculine as a value for GEND in the daughter. So only *CI-masc* and *CII-masc* are possible input. The elementary predication is inserted and the ARG1 of the added relation is structure-shared with the ARG0 of the referent.

6 Conclusion

A solution for the so-called gender flexibility in Tigrinya was presented. Storing some nouns with both genders raises the problem of reduplication in the lexicon. Further, having their value underspecified undermines the internal structure of controllers in the language and the nature of a shift. Nouns should be encoded with one value for gender. The semantic criteria (in section 3) together with the notion of evaluation (in section 4) predict a *class-I* and *class-II* dichotomy. The former is derived from the assignment of a set of semantic criteria and the latter is considered residual. Evidences show that masculine was the right default assignment for *class-II*. If a noun's value for gender shifts, that noun has undergone an evaluation. Evaluations are gathered under the term Category E, which subsumes all the phenomena that received an analysis compatible with those described. In an HPSG format, the type *cat-E* roots a set of lexeme-to-lexeme rules which basically shifts the value for the feature GEND and add an EP in the RELS' list. Following this approach, semantically-driven transfer becomes eligible between analytic and synthetic types of languages (i.e. morphological vs. syntactical composition of EPs) and between languages in which evaluative morphology is either present or absent.

References

- Agostinos, Tadla. 1994. *La Lingua Abissinia*. Adveniat Regnum Tuum.
- Awedoba, Albert K. 2003. Criteria for noun classification in Kasem. In von Roncador, Manfred, Kerstin Winkelmann, and Ulrich Kleinewillinghöfer, eds., *Gur papers/Cahiers Voltaïques*, 6. Afrikanistik I, Universität Bayreuth.
- Beard, Robert. 1995. *Lexeme-Morpheme Base Morphology*. State University of New York Press.
- Bender, Emily M., Dan Flickinger, and Stephan Oepen, 2003. The Grammar Matrix: An Open-Source Starter-Kit for the Rapid Development of Cross-Linguistically Consistent Broad-Coverage Precision Grammars. Tech. rep., Center for the Study of Language and Information, Stanford University.

Figure 13: *ge-sh-fem-cari-rule*

“A asks B how C (Solomon) is doing. A and B are close friends with C. By using the feminine on male entity, A is expressing his affection toward C.”

fomon kamay ti-sarih ?all-a
 Solomon how IPFV.FEM.SG.work have-FEM.SG
 ‘How is Solomon doing? (*evaluated*)’

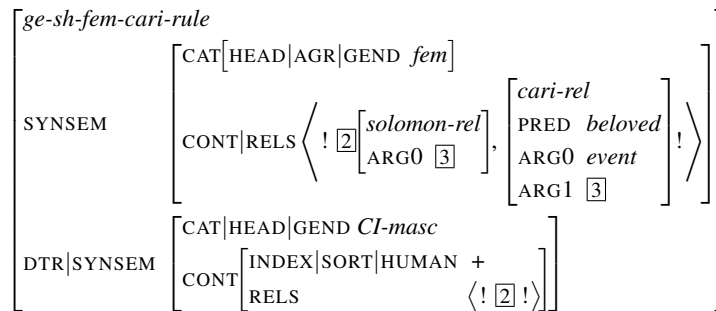
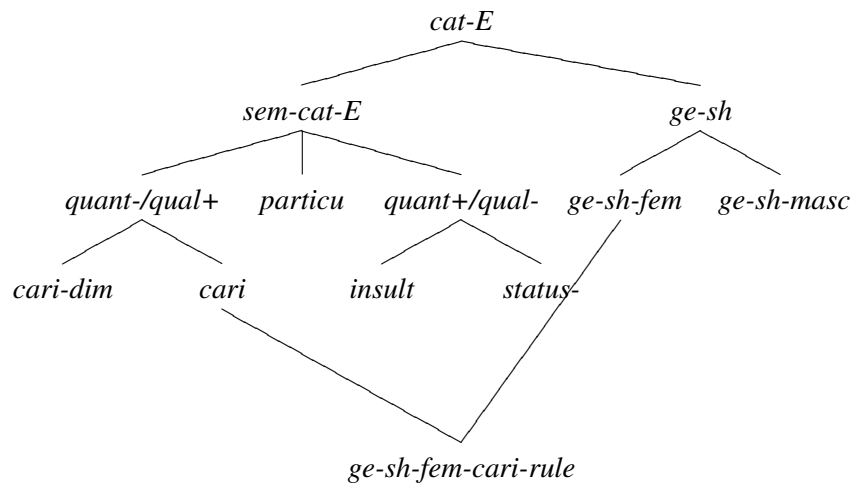

- de Blois, Kees F. 1970. The augment in Bantu languages. *Africana Linguistica*, 4:85–165.
- Borthen, Kaja. 2003. *Norwegian Bare Singulars*. Ph.D. thesis, Norges teknisk-naturvitenskapelige universitet.
- Borthen, Kaja and Petter Haugereid. 2004. Representing referential properties of nominals. *Research on Language and Computation*, 3:221–246. Springer.
- Brindle, Jonathan Allen, 2005a. *On the notion of Bare and Evaluated Controllers in Tigrinya*. Master's thesis, Norges teknisk-naturvitenskapelige universitet.
- Brindle, Jonathan Allen, 2005b. Tigräi: Fieldwork Report. Manuscript.
- Brown, Roger W. and Albert Gilman. 1960. The Pronouns of Power and Solidarity. In Sebeok, Thomas A., ed., *Style in Language*. M.I.T. Press.
- Copestake, Ann, Dan Flickinger, Carl Pollard, and Ivan A. Sag. 2006. Minimal Recursion Semantics: an Introduction. *Research on Language and Computation*, 3(4):281–332.
- Corbett, Greville. 1991. *Gender*. Cambridge Textbooks in Linguistics. Cambridge University Press.
- Corbett, Greville. 2001. Agreement: terms and boundaries. William Griffin (Ed.) "The Role of Agreement in Natural Language".
- Corbett, Greville G. 2006. *Agreement*. Cambridge Textbooks in Linguistics. Cambridge University Press.
- Corbett, Greville G. and Norman M. Fraser. 2000. Gender assignment: a typology and a model. In Senft, Gunter, ed., *Systems of Nominal Classification*, no. 4 in language, culture and cognition. Cambridge University Press.
- Das, Sisir Kumar. 1968. Forms of Address and Terms of Reference in Bengali. *Anthropological Linguistics*, 10(1).
- Delhay, Corinne. 1996. *Il était un "petit X"*. Institut Pierre Larousse.
- Derzhanski, Ivan A. 2003. On Diminutive Plurals and Plural Diminutives. In Booij, G., E. Guevara, A. Ralli, S. SgROI, and S. Scalise, eds., *Morphology and Linguistic Typology*. <http://morbo.lingue.unibo.it/mmm/>.
- Eynde, Frank Van. 2002. Morpho-Syntactic Agreement and Index Agreement in Dutch NPs. *Computational Linguistics in the Netherlands 2002*.
- Gebrechristos, Solomon. 1993. *Idiomatic Expressions of Tigrinya*. Asmara: Tipografia Francescana.

- Geertz, Clifford. 1960. Linguistic Etiquette. In *Religion in Java*. New York: Glencoe Press.
- Grandi, Nicola and Fabio Montermini. 2003. Prefix-Suffix Neutrality in Evaluative Morphology. In Booij, G., E. Guevara, A. Ralli, S. Sgroi, and S. Scalise, eds., *Morphology and Linguistic Typology*. <http://morbo.lingue.unibo.it/mmm/>.
- Hasselrot, Bengt. 1957. *Etudes sur La Formation Diminutive dans Les Langues Romanes*. Acta Universitatis Upsaliensis.
- Hyman, Larry M. and Francis X. Katamba. 1993. The Augment in Luganda: Syntax or Pragmatics? In Mchombo, Sam A., ed., *Theoretical Aspects of Bantu Grammar*. CSLI Publications.
- Junker, M.-O, L. Salt, and F. Visitor, 2002. East Cree Nouns (Northern dialect). <http://www.grammar.eastcree.org>.
- Kathol, Andreas. 1999. Agreement and the syntax-morphology interface in HPSG. In Levine, Robert D. and Georgia M. Green, eds., *Studies in Contemporary Phrase Structure Grammar*, pages 223–274. Cambridge University Press.
- Law, 1918. *Customary Law of Karnasem*. Tipografia Francescana, Asmara. Second part.
- Law, 1946. *Customary Law of Adgena Tagalaba*. Tipografia Pietro Silla, Asmara. Chapter 16.
- Leslau, Wolf. 1941. *Document Tigrigna*. La Société de Linguistique de Paris - XLVIII.
- Lipiński, Edward. 2001. *Semitic Languages Outline of a Comparative Grammar*, vol. 80 of *Orientalia Lovaniensia Analecta*. Peeters edition and Department of Oriental Studies, second edn.
- Petzell, Malin. 2003. What is the function of the pre-prefix in Kagulu? *langue.doc*. https://guoa.ub.gu.se/dspace/bitstream/2077/22/8/Petzell_M_2003.pdf.
- Sag, Ivan A., Thomas Wasow, and Emily M. Bender. 2003. *Syntactic Theory: a Formal Introduction*. CSLI Publications.
- Schreiber, J. 1887. *Manuel de la langue Tigraï*. Vienne: Librairie de la Cour Impériale et Royale.
- Slobin, Dan I. 1963. Some Aspects of the Use of Pronoun of Address in Yiddish. *Word*.